



**InstruTech®**

**Series 301 Busy Bee™ Pirani Capacitance Vacuum Gauge**

**Wide measurement range**

3.8 x 10<sup>-5</sup> to 1,125 Torr

5 x 10<sup>-5</sup> to 1,500 mbar

5 x 10<sup>-3</sup> Pa to 150 kPa

Pirani sensor combined with robust ceramic capacitance diaphragm gauge provides gas independent measurements above 7.6 Torr

Gas independent measurements above 7.6 Torr allows for safe venting of any gas mixture

*Built-in backlit display, two setpoint relays, log-linear analog output and an optional atmospheric switch*

*Accurate and repeatable for reliable and fast atmospheric pressure readings*

*Can be mounted in any orientation*

*Sensor with on-board calibration data can be easily replaced in the field*



**PCM301 Busy Bee**

The PCM301 Busy Bee™ module is ideal for applications from medium vacuum to above atmosphere. The unit combines pirani technology with a ceramic capacitance diaphragm sensor to provide repeatable and accurate pressure measurements. Above 7.6 Torr, the instrument is gas type independent which allows for safe venting with any gas mixture.

The instrument is offered standard with a built-in backlit display and two set point relays providing flexibility for a variety of process control schemes. It can be mounted in any orientation for easy adaption of any tool design.

The PCM301 Busy Bee pirani capacitance vacuum gauge

module provides the basic signal conditioning required to turn the sensor into a complete vacuum pressure measurement instrument.

At low pressures, only the signal of the pirani sensor is used for pressure measurements while at high pressures, only the signal of the diaphragm capacitive sensor is utilized. To determine the output signal in the intermediate range, both signals are used proportionally to accurately determine the pressure throughout the measurement range of the device.

The combination of superior sensor design and enhanced signal processing provides optimal and stable pressure readings over the entire measurement range.

**Specifications**

measurement range	3.8 x 10 <sup>-5</sup> to 1,125 Torr / 5 x 10 <sup>-5</sup> to 1,500 mbar / 5 x 10 <sup>-3</sup> Pa to 150 kPa
accuracy - N <sub>2</sub> (typical)	3.8 x 10 <sup>-4</sup> to 7.6 x 10 <sup>-4</sup> Torr: ± 50% of reading 7.6 x 10 <sup>-4</sup> to 75 Torr: ± 15% of reading 75 to 715 Torr: ± 5% of reading 715 to 790 Torr: ± 2.5% of reading
repeatability - (typical)	7.6 x 10 <sup>-4</sup> to 825 Torr: ± 2% of reading
materials exposed to gases	W, Ni, NiFe, Al <sub>2</sub> O <sub>3</sub> , SnAg, stainless steel, glass
internal gauge volume	1/8 in. NPT: 0.32 in <sup>3</sup> (5.2 cm <sup>3</sup> ), KF16: 0.29 in <sup>3</sup> (4.7 cm <sup>3</sup> ), KF25 & 4 VCR: 0.34 in <sup>3</sup> (5.5 cm <sup>3</sup> ) 1.33 in. Mini-CF: 0.49 in <sup>3</sup> (8 cm <sup>3</sup> ), 8 VCR: 0.43 in <sup>3</sup> (7 cm <sup>3</sup> ) 16KF long tube: 0.88 in <sup>3</sup> (14.5 cm <sup>3</sup> ), 1.33 in. Mini-CF long tube: 0.85 in <sup>3</sup> (14 cm <sup>3</sup> )
admissible pressure	≤ 72.5 psi (5 bar) absolute
temperature	operating: + 10 to + 50 °C storage: -20 to + 65 °C
bakeout temperature	≤ 80 °C at flange ≤ 250 °C at flange with the long tube option
weight	4 to 4.5 oz. (115 to 130 g)
housing (electronics)	aluminum extrusion
mounting orientation	any
analog output	log-linear 0 to 8 Vdc, 1 V/decade
error signal	analog output switches to 0 V
response time	< 30 ms

input power	15 to 30 Vdc, $\leq 2.5$ W protected against power reversal
supply voltage ripple	$\leq 1$ p-p
setpoint relays	2 Solid State, normally open, potential free, $<30$ V (ac) / (dc), $\leq 0.3$ A resistive
setpoint relay hysteresis	10% of threshold
setpoint relay range (N <sub>2</sub> )	$3.8 \times 10^{-5}$ to 1,125 Torr
connector	9-pin D-sub male
CE compliance	EMC (EN61000-6-2, EN61000-6-3, EN61010)
environmental	RoHS compliant

Fitting	dimension A
1/8 in. NPT	1.41 in. (36 mm)
NW16KF	0.57 in. (14.5 mm)
NW25KF	0.85 in. (21.5 mm)
1 1/3 in. Mini-CF	1.22 in. (30.9 mm)
1/4 in. Cajon 4VCR	1.68 in. (42.7 mm)
1/2 in. Cajon 8VCR	1.82 in. (46.3 mm)
NW16KF w. Long Tube	5.15 in. (130.8 mm)
1 1/3 in. Mini-CF w. Long Tube	5.13 in. (130.2 mm)

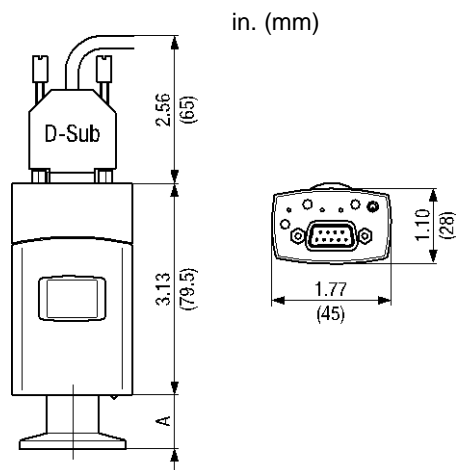

### Ordering Information

### PCM301 Part Number

### Spare Parts / Accessories Part Numbers

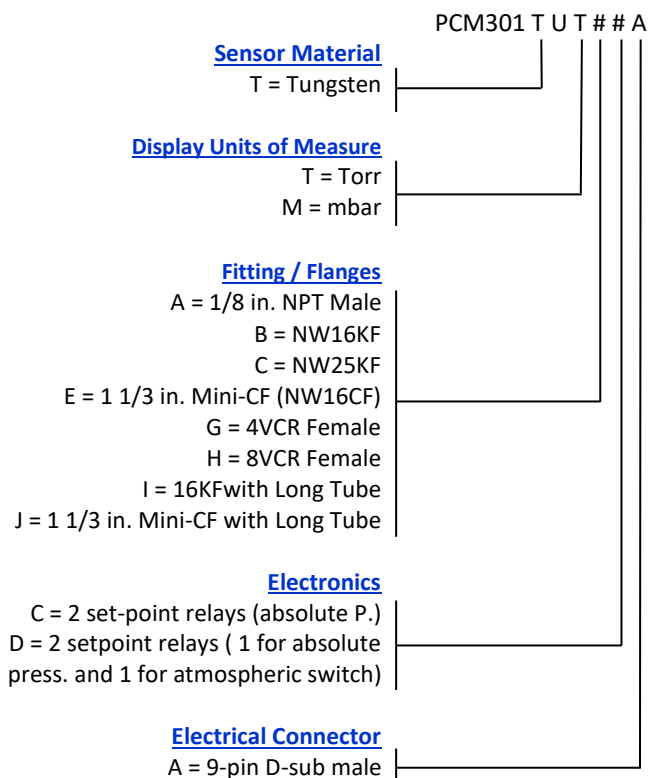

PCM301 Spare Sensor, 1/8 in. NPT Male	PC3A
PCM301 Spare Sensor, NW16KF	PC3B
PCM301 Spare Sensor, NW25KF	PC3C
PCM301 Spare Sensor, 1 1/3 in. Mini-CF	PC3E
PCM301 Spare Sensor, 4 VCR Female	PC3G
PCM301 Spare Sensor, 8 VCR Female	PC3H
PCM301 Spare Sensor, 16KF Long Tube	PC3BL
PCM301 Spare Sensor, 1 1/3 in. Mini-CF Long Tube	PC3EL
Centering ring with fine filter, NW16 KF	IL002628

Example: PCM301TUTBCA (PCM301 tungsten pirani sensor, Torr display, NW16KF fitting, two setpoint relays, 9-pin D-Sub Connector)



**InstruTech®**

1475 S. Fordham Street  
Longmont, CO 80503  
USA

Phone +1-303-651-0551  
Fax +1-303-678-1754  
E-mail [info@instrutechinc.com](mailto:info@instrutechinc.com)  
Web [www.instrutechinc.com](http://www.instrutechinc.com)