



**InstruTech<sup>®</sup>, Inc.**

**Vacuum Gauge Controller  
B-RAX 3000**



**User Manual**

InstruTech, Inc.  
1475 S. Fordham St.  
Longmont, CO 80503  
USA

Phone: +1-303-651-0551  
Fax: +1-303-678-1754  
E-mail [info@instrutechinc.com](mailto:info@instrutechinc.com)  
[www.instrutechinc.com](http://www.instrutechinc.com)

## Important User Information

There are operational characteristic differences between solid state equipment and electromechanical equipment. Because of these differences, and because there are a variety of uses for solid state equipment, all persons that apply this equipment must take every precaution and satisfy themselves that the intended application of this equipment is safe and used in an acceptable manner.

In no event will InstruTech, Inc. be responsible or liable for indirect or consequential damages that result from the use or application of this equipment.

Any examples or diagrams included in this manual are provided solely for illustrative purposes. Because of the many variables and requirements imposed on any particular installation, InstruTech, Inc. cannot assume responsibility or liability for any actual use based on the examples and diagrams.

No patent liability is assumed by InstruTech, Inc. with respect to use of information circuits, equipment, or software described in this manual.

Throughout this manual we use notes, notices and apply internationally recognized symbols and safety messages to make you aware of safety considerations.

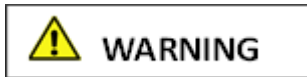

Identifies information about practices or circumstances that can cause electrical or physical hazards which, if precautions are not taken, could result in death or serious injury, property damage, or economic loss.



Identifies information about practices or circumstances that can cause electrical or physical hazards which, if precautions are not taken, could result in minor or moderate injury, property damage, or economic loss.

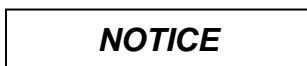

Identifies information that is critical for successful application and understanding of the product.



Labels may be located on or inside the device to alert people that dangerous voltages may be present.

---

*Copyright © 2012 by InstruTech®, Inc.*

*All rights reserved. No part of this work may be reproduced or transmitted in any form or by any means, electronic or mechanical, including photocopying and recording, or by any information storage or retrieval system, except as may be expressly permitted in writing by InstruTech, Inc.*

*Printed in the United States of America*

Granville-Phillips® and Convectron® are registered trademarks of MKS Instruments, Andover, MA  
Conflat® is a registered trademark of Varian, Inc. / Agilent Technologies, Lexington, MA.  
Teflon® is a registered trademark of E. I. du Pont de Nemours and Company, Wilmington, DE.

## Table of Contents

1	Introduction / General Information.....	5
1.1	Description .....	5
1.2	Specifications .....	6
1.3	Dimensions.....	7
1.4	Part Numbers .....	7
2	Important Safety Information.....	8
2.1	Safety Precautions - General.....	8
2.2	Safety Precautions - Service and operation .....	9
2.3	Electrical Conditions.....	9
2.3.1	Proper Equipment Grounding .....	9
2.3.2	Electrical Interface and Control.....	10
2.4	Overpressure and use with Hazardous Gases.....	10
2.5	Gases other than Nitrogen / air .....	10
3	Installation .....	12
3.1	Mechanical .....	12
3.1.1	Panel Mount.....	12
3.1.2	Rack Mount .....	13
3.2	Electrical Installation .....	14
3.2.1	Grounding.....	14
3.2.2	Installation.....	14
3.2.3	IEC 60320 AC Power Input.....	15
3.2.4	Connecting the IGM400 or CCM500 - connector labeled IG.....	15
3.2.5	Connecting the CVG101 - connectors labeled CG1 and CG2 .....	16
3.2.6	Relay Connectors.....	16
3.2.7	Alternate gauge installation .....	17
4	Setup and Operation.....	18
4.1	Applying power .....	18
4.2	Emission Current - IGM400 only .....	19
4.3	Degas - IGM400 only .....	19

4.4	IGM400 Filament Material Selection / Venting the Chamber .....	20
4.5	Overpressure shut down - IGM400 and CCM500 .....	21
4.6	User Interface Basics .....	22
4.7	Factory-Set Default Parameters.....	23
4.8	Programming.....	24
4.8.1	SETUP IG - IGM400.....	24
4.8.2	SETUP IG - CCM500 .....	28
4.8.3	SETUP CG.....	29
4.8.4	SETUP UNIT .....	31
5	Using the Gauge with different gases.....	33
5.1	Ion gauge display correction factors for selected gases .....	33
5.2	Effects of different gases on convection gauge display .....	34
6	Service.....	38
6.1	Calibration .....	38
6.2	Troubleshooting - IGM400 Operation.....	38
6.3	Troubleshooting - IGM400 Error Messages .....	39
6.4	Troubleshooting - CCM500 Operation .....	40
6.5	Troubleshooting - CCM500 Error Messages.....	41
6.6	Clearing Errors.....	42
6.7	Programming the B-RAX for the Research screen in the LCD display.....	43
6.7.1	Research (R & D) Diagnostic Display - IGM400 .....	44
6.7.2	Research (R & D) Diagnostic Display - CCM500.....	47
6.8	Maintenance .....	47
7	Factory Service and Support .....	48
8	Warranty.....	48

## 1 Introduction / General Information

### 1.1 Description

The *B-RAX 3000* is a vacuum pressure measurement system which is comprised of the following:

- The *B-RAX 3000* Vacuum Gauge Controller
- Either the IGM400 hot cathode or the CCM500 cold cathode ionization gauge module
- One or two InstruTech *Worker Bee* CVG101 convection enhanced pirani transducers<sup>1</sup>
- Cables to interconnect the *B-RAX 3000* and point-of-use devices

An alternate vacuum gauge transducer such as a capacitance diaphragm gauge can be used instead of the second convection gauge. In this case, a two conductor cable to connect the analog output voltage proportional to pressure measured by that device will be required for connection to the *B-RAX 3000* Analog Input connector located on the back panel.

Typical components of the complete measurement system are shown in the figure below. The *B-RAX 3000* provides power and operating control for either the IGM400 or the CCM500 ion gauge module. Additionally, it provides power and operating control for two convection gauges.



**Typical Components of the complete Vacuum Pressure Measurement System**

<sup>1</sup> The *B-RAX 3000* will also operate the Granville-Phillips® Convectron® convection enhanced pirani gauge transducer.

Whether you choose the IGM400 or the CCM500, you will enjoy the benefits of InstruTech’s novel design approach for this multiple transducer vacuum pressure measurement system. Departing from the traditional vacuum gauge controller approach of the past, the *B-RAX 3000* provides a compact, low power, cost effective solution for controlling the operation of one ionization gauge (IG) module and two convection enhanced pirani transducers (often referred to as a Convection Gauge or CG). The traditional controller designs incorporate the IG power supplies and ion current measurement circuitry inside a separate controller unit requiring connection to the IG transducer via complex cabling systems. The *B-RAX 3000* system, utilizing the design concept of integrating the power, control and ion current measurement circuitry inside the IGM400 and CCM500 devices connected at the point of vacuum measurement, minimizes overall complexity, cost and space requirements.

The *B-RAX 3000*, a controller unit capable of controlling multiple gauge transducers, is either rack or instrument panel mountable. The clean, space saving design of the *B-RAX 3000* enclosure lends itself to an appealing device for bench-top use. Optional industry standard 19-inch, 2U high rack-mount panels are available to mount the B-RAX into rack enclosures.

### 1.2 Specifications

measurement range: (vacuum gauge dependent)		1.0 x 10 <sup>-9</sup> to 1000 Torr / 1.3 x 10 <sup>-9</sup> to 1333 mbar / 1.3 x 10 <sup>-7</sup> Pa to 133 kPa 1.0 x 10 <sup>-9</sup> to 5 x 10 <sup>-2</sup> Torr when used with the IGM400 hot cathode ionization gauge 1.0 x 10 <sup>-8</sup> to 1 x 10 <sup>-2</sup> Torr when used with the CCM500 cold cathode ionization gauge 1.0 x 10 <sup>-4</sup> to 1000 Torr when used with convection gauges
display	pressure	3 independent display channels - 3 digit plus 2 digit exponent LED per channel displays pressure measurement of one ion gauge, two convection gauges or alternate gauge
	engineering units	Torr, mbar, Pa - user selectable
functionality	ionization gauge convection gauge alternate gauge (B-RAX 3000 only)	operates one InstruTech IGM400 or CCM500 ionization vacuum gauge module operates up to two InstruTech CVG101 convection or Granville-Phillips® Convectron® gauges 1 alternate 0-10 Vdc analog input from other gauges such as a capacitance manometer
IGM400 filament control		user selectable between filament 1 or 2 using front panel push buttons
IGM400 emission current		100 μA, 4 mA, or automatic switching between 100 μA and 4 mA
IGM400 degas		3 W, electron bombardment
IGM400 overpressure protection		turns off ion gauge at a factory default setting of 5 x 10 <sup>-2</sup> Torr
CCM500 overpressure protection		turns off ion gauge at a factory default setting of 1 x 10 <sup>-2</sup> Torr
IGM400 status		emission current, relay, filament and degas on/off status displayed on set up screen
temperature		operating; 0 to + 40 °C storage; -40 to + 70 °C
humidity		0 to 95% Relative Humidity, non-condensing
altitude		operating; 8,200 ft. (2,500 m) max storage; 41,000 ft. (12,500 m) max
weight		3.6 lb. (1.62 kg)
housing		aluminum extrusion
analog output (B-RAX 3100 only)		analog output voltage signal is available only with the B-RAX 3100 model.
setpoint relays		3 user programmable single-pole, double-throw (SPDT), 1 A at 30 Vdc resistive, or ac non-inductive. Multiple relays assignable to one gauge or one relay per gauge.
source power		100-240 Vac, 50/60Hz, 150 W max, universal input power
CE compliance		EMC Directive 2004/108/EC, EN61326-1, EN55011 Low Voltage Directive 2006/95/EC, EN61010-1
environmental		RoHS compliant

**NOTICE** - For important information about the CVG101 *Worker Bee™* convection gauge, CCM500 cold cathode ionization gauge and IGM400 *Hornet™* hot cathode ionization gauge products, please refer to the User Manual for each of these products. Read the User Manuals in their entirety for any device you intend to connect to the *B-RAX 3000* prior to connecting and using the external devices and cables that the *B-RAX 3000* is intended to be used with.

### 1.3 Dimensions

#### Front View

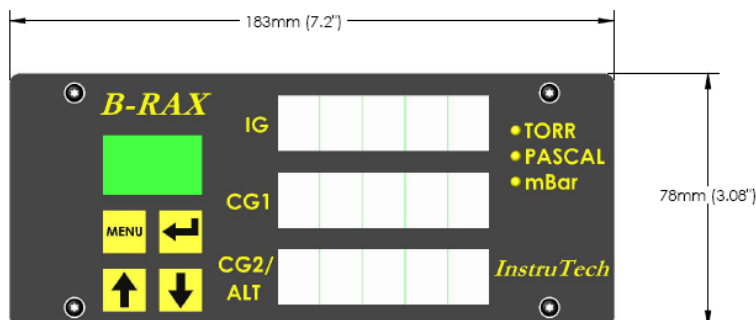

#### Side View



### 1.4 Part Numbers

<b>B-RAX3000</b> (3 display channels, 3 set-point relays, no analog output, one alternate analog input from a CDG) <i>(includes mating interface connectors, power cord &amp; plug.)</i>	B-RAX 3000
---	------------

<b>IGM400 or CCM500 ionization gauge</b>	See IGM400 or CCM500 Hornet™ ionization gauge User Manuals
<b>CVG101 convection gauge</b>	See CVG101 Worker Bee™ convection gauge User Manuals

Cables	IGM400 and CCM500 ionization gauge cable	CVG101 convection gauge cable
10 FT (3 m)	BXC400-1-10F	CB421-1-10F
25 FT (8m)	BXC400-1-25F	CB421-1-25F
50 FT (15m)	BXC400-1-50F	CB421-1-50F
> 50 FT	Consult factory	Consult factory

Optional Rack Mount Adapter	
Rack Mount adapter panel for installation of one B-RAX in center of a 19 inch rack	000849
Rack Mount adapter panel for installation of two B-RAX side-by-side in a 19 inch rack	001007



## 2 Important Safety Information

InstruTech has designed and tested this product to provide safe and reliable service, provided it is installed and operated within the *strict safety guidelines provided in this manual*. **Please read and follow all warnings and instructions.**



**To avoid serious injury or death, follow the safety information in this document. Failure to comply with these safety procedures could result in serious bodily harm, including death, and or property damage.**

Failure to comply with these warnings violates the safety standards of installation and intended use of this instrument. InstruTech, Inc. disclaims all liability for the customer's failure to comply with these instructions.

Although every attempt has been made to consider most possible installations, InstruTech cannot anticipate every contingency that arises from various installations, operation, or maintenance of the module. If you have any questions about the safe installation and use of this product, please contact InstruTech.

This device meets FCC part 15 requirements for an unintentional radiator, class A.

### 2.1 Safety Precautions - General

Hazardous voltages are present with this product during normal operation. The product should never be operated with the covers removed unless equivalent protection of the operator from accidental contact with hazardous internal voltages is provided.

 **WARNING!** There are no operator serviceable parts or adjustments inside the product enclosure; refer servicing to service trained personnel.

Do not modify this product or substitute any parts without authorization of qualified InstruTech service trained personnel. Return the product to an InstruTech qualified service and repair center to ensure that all safety features are maintained. Do not use this product if unauthorized modifications have been made.

 **WARNING!** Source power must be removed from the product prior to performing any servicing.

After servicing this product, ensure that all safety checks are made by a qualified service person. When replacement parts are required, ensure that the parts are specified by InstruTech. Substitutions of non-qualified parts may result in fire, electric shock or other hazards. Use of unauthorized parts or modifications made to this product will void the warranty.

To reduce the risk of fire or electric shock, do not expose this product to rain or moisture. These products are not waterproof and careful attention must be paid to not spill any type of liquid onto these products. Do not use these products if they have been damaged. Immediately contact InstruTech, Inc. to arrange return of the product if it is damaged.

Due to the possibility of corrosion when used in certain environmental conditions, it is possible that the product's safety could be compromised over time. It is important that the product be periodically inspected for sound electrical connections and equipment grounding. Do not use if the equipment grounding or electrical insulation has been compromised.

## **2.2 Safety Precautions - Service and operation**

Ensure the enclosure of the B-RAX is connected directly to a good quality earth ground.

Ensure that the vacuum port on which the vacuum gauge sensors are mounted is electrically grounded.

Use an appropriate power source of 100-240 Vac, 50/60Hz or 12 to 30 Vdc, 150 W.

Turn off power to the unit before attempting to service the controller.

Turn off power to the unit if a cable or plug is damaged or the product is not operating normally according to this instruction manual. Contact qualified InstruTech service personnel for any service or troubleshooting condition that may not be covered by this instruction manual.

It is important that the product be periodically inspected for sound electrical connections and equipment grounding. Do not use if the equipment grounding or electrical insulation has been compromised.

Do not use if the unit has been dropped or the enclosure has been damaged. Contact InstruTech for return authorization and instructions for returning the product to InstruTech for evaluation.

## **2.3 Electrical Conditions**

 **WARNING!** When high voltage is present in any vacuum system, a life threatening electrical shock hazard may exist unless all exposed electrical conductors are maintained at earth ground potential. This applies to all products that come in contact with the gas contained in vacuum chambers. An electrical discharge within a gaseous environment may couple dangerous high voltage directly to any ungrounded conductor of electricity. A person could be seriously injured or killed by coming in contact with an exposed, ungrounded electrical conductor at high voltage potential. This condition applies to all products that may come in contact with the gas inside the vacuum chamber (vacuum/pressure containment vessel).

### **2.3.1 Proper Equipment Grounding**

 **WARNING!** Hazardous voltages that could seriously injure or cause death are present in many vacuum processes. Verify that the vacuum connection ports on which the ion gauge and the convection gauges are mounted are electrically grounded. Consult a qualified Electrician if you are in doubt about your equipment grounding. Proper grounding of your equipment is essential for safety as well as intended operation of the equipment. The vacuum gauge transducers and enclosure of any control module must be connected directly to a good quality equipment earthing conductor. Use a ground lug on the vacuum connection flange of the pressure measurement devices if necessary.

**⚠ WARNING!** In order to protect personnel from electric shock and bodily harm, shield all conductors which are subject to potential high voltage electrical discharges in or around the vacuum system.

### **2.3.2 Electrical Interface and Control**

It is the user's responsibility to ensure that the electrical signals from this product and any connections made to external devices, for example, relays and solenoids, are used in a safe manner. Always double check the system set-up before using any signals to automate your process. Perform a hazardous operation analysis of your system design and ensure safeguards and personnel safety measures are taken to prevent injury and property damage.

### **2.4 Overpressure and use with Hazardous Gases**

**⚠ WARNING!** Install suitable protective devices that will limit the level of pressure inside your vacuum chamber to less than what the vacuum chamber system components are capable of withstanding.

In cases where an equipment failure could cause a hazardous condition, always implement fail-safe system operation. For example, use a pressure relief device in an automatic backfill operation where a malfunction could result in high internal pressures if the pressure relief device was not installed on the chamber.

The vacuum gauge transducers used with this product are not intended for use at pressures above 20 psia (1000 torr); DO NOT exceed 35 psig (< 2 ½ bars) pressure inside the sensor. If your chamber goes to higher pressures, you should install an isolation valve or pressure relief device to protect the gauge tube from overpressure conditions. With some fittings, actual safe overpressure conditions may be lower; for example, a quick-connect, O-ring compression fitting may forcibly release the gauge tube from the vacuum chamber fitting with only a few psi over local uncorrected barometric (atmospheric) pressure.

**⚠ CAUTION!** If the internal pressure of a vacuum gauge device is allowed to increase above local uncorrected barometric pressure (atmospheric pressure side), vacuum fittings may release and possible overpressure conditions may cause leaks that would allow the gas inside the gauge tube to release into the atmosphere of the surrounding environment. Toxic, pyrophoric and flammable gases are examples of hazardous gases that if allowed to leak out of the vacuum/pressure containment vessel into the atmospheric environment, could cause bodily injury and possible damage to equipment. Never expose the gauge tube internal volume to pressure above local atmospheric pressure when using hazardous gases.

### **2.5 Gases other than Nitrogen / air**

**⚠ WARNING!** Do not attempt to use with gases other than nitrogen (N<sub>2</sub>) or air without referring to correction factor data tables.

InstruTech gauges and modules are calibrated for direct readout of nitrogen or air. Do not attempt to use with other gases such as argon (Ar) or carbon dioxide (CO<sub>2</sub>) unless you have applied correction factors to both the displayed pressure and the analog output to determine the true measured pressure. This is particularly critical when using convection gauges to measure pressure of gases other than N<sub>2</sub>/Air.

 **WARNING!** Do not use the IGM400 in an explosive atmosphere or in the presence of flammable gases, vapors or fumes. Do not use the IGM400 to measure the pressure of explosive or combustible gases or gas mixtures. The sensor filaments operate at incandescent temperatures and could become an ignition source. This could cause an explosion which could result in serious injury or death.

 **WARNING!** Do not use the CVG101 in an explosive atmosphere or in the presence of flammable gases, vapors or fumes. Do not use the CVG101 to measure the pressure of explosive or combustible gases or gas mixtures. The sensor wire in the gauge normally operates at 125 °C, but if malfunction should occur, the wire temperature could exceed the ignition temperature of certain combustible gases and gas mixture. This could cause an explosion which could result in serious injury or death.

### 3 Installation

#### 3.1 Mechanical

The B-RAX 3000 is intended for indoor use only.

The B-RAX is offered as a space saving half rack design. It may also be used as a bench top device or easily installed in an instrument panel. Optional EIA-standard rack mount panels are available for either full rack or dual, side-by-side rack mount installation.



**B-RAX 3000 Vacuum Gauge Controller Installation**

##### 3.1.1 Panel Mount

To install the B-RAX in a rack or instrument control panel follow the steps outlined below:

1. Make a cutout in your rack panel or instrument control panel as shown in the drawing below. Be sure to allow clearance behind the panel for the instrument as well as connectors and cables at the back of the instrument. Optional EIA-standard, 19-inch, 2U height rack mount panels are available from InstruTech, Inc. The optional rack mount panels are provided with panel cutouts and mounting holes to allow efficient mounting of your B-RAX unit.

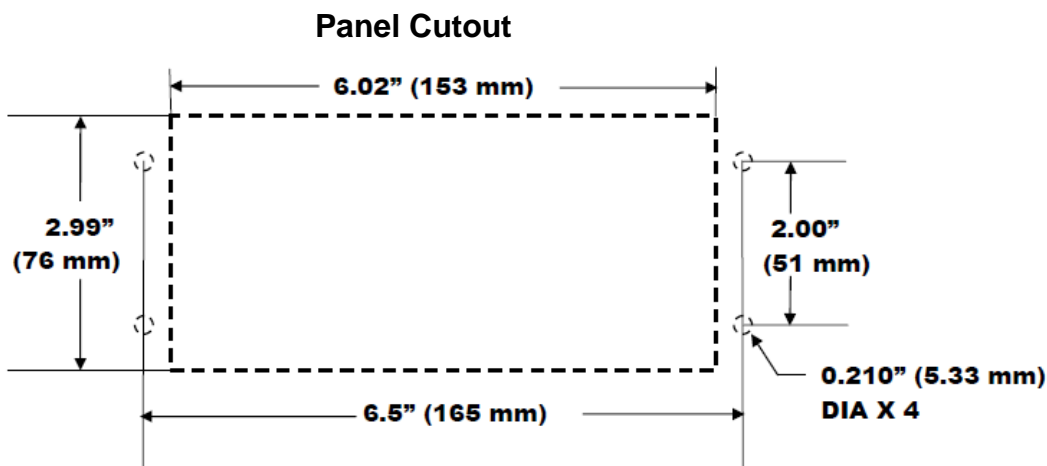

2. Drill four guide holes on each side of the panel cut out (two on each side) with dimensions as shown in the panel cut-out drawing above.
3. Slide the B-RAX into the panel hole cut-out. Guide the four studs on the back of the B-RAX front panel face plate thru the four holes next to the panel cut-out.
4. Use four # 10-32 Hex Nut (provided with instrument) to tighten the B-RAX to the panel.

### 3.1.2 Rack Mount

Optional EIA-standard 19-inch wide, 2U height rack mount panels available from InstruTech:

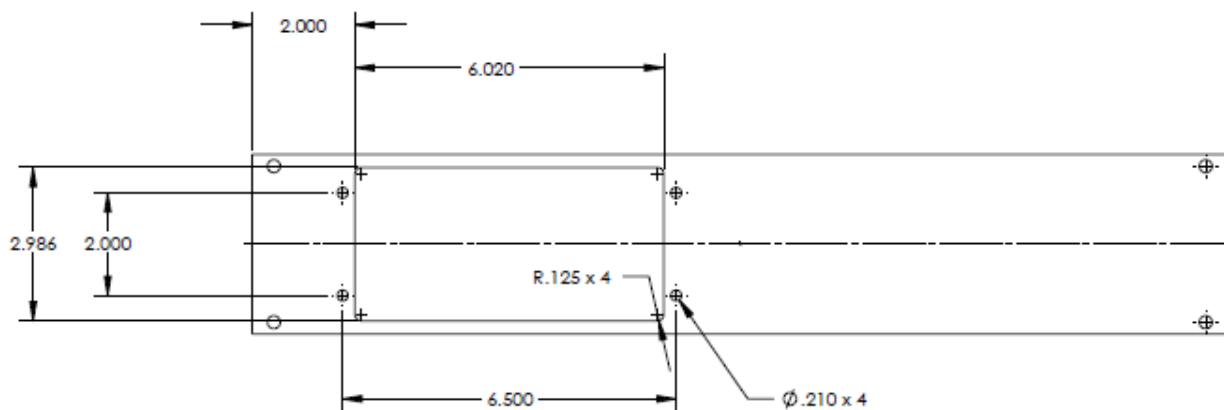

Single cut-out panel (InstruTech p/n 00849) - All dimensions in inches

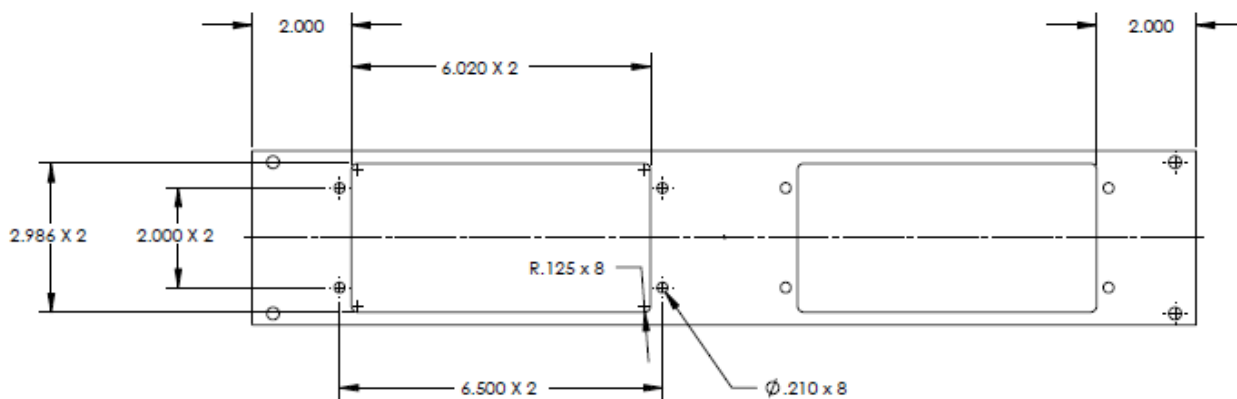

Dual cut-out panel (InstruTech p/n 001007) - All dimensions in inches

The single cut-out and dual cut-out rack mountable panels shown above are available from InstruTech. Panel color matches the front panel of B-RAX units. Screws for mounting to rack enclosure are user provided.

### 3.2 Electrical Installation

#### 3.2.1 Grounding

**⚠** Be sure the vacuum gauges and the rest of your vacuum system are properly grounded to protect personnel from shock and injury. Be aware that some vacuum fittings, especially those with O-rings when not used with metal clamps, may not produce a good electrical connection between the gauge and the chamber it is connected to. Use a ground lug on the vacuum connection flange of the pressure measurement device if necessary. The B-RAX control unit should be connected to earth ground via a good quality equipment earthing conductor. The IEC 60320 type AC Mains power cord set provided with your B-RAX is intended to connect facility earth ground to the B-RAX enclosure. It is encouraged that you connect a separate 12-AWG earthing conductor between a known facility earth ground connection and the location marked with the earth ground symbol (via the green colored screw provided) on the back panel of the B-RAX.

#### 3.2.2 Installation

A good, recommended practice is to remove power from any cable prior to connecting or disconnecting it. The electrical connections for the B-RAX are located on the back panel of the device as shown below.

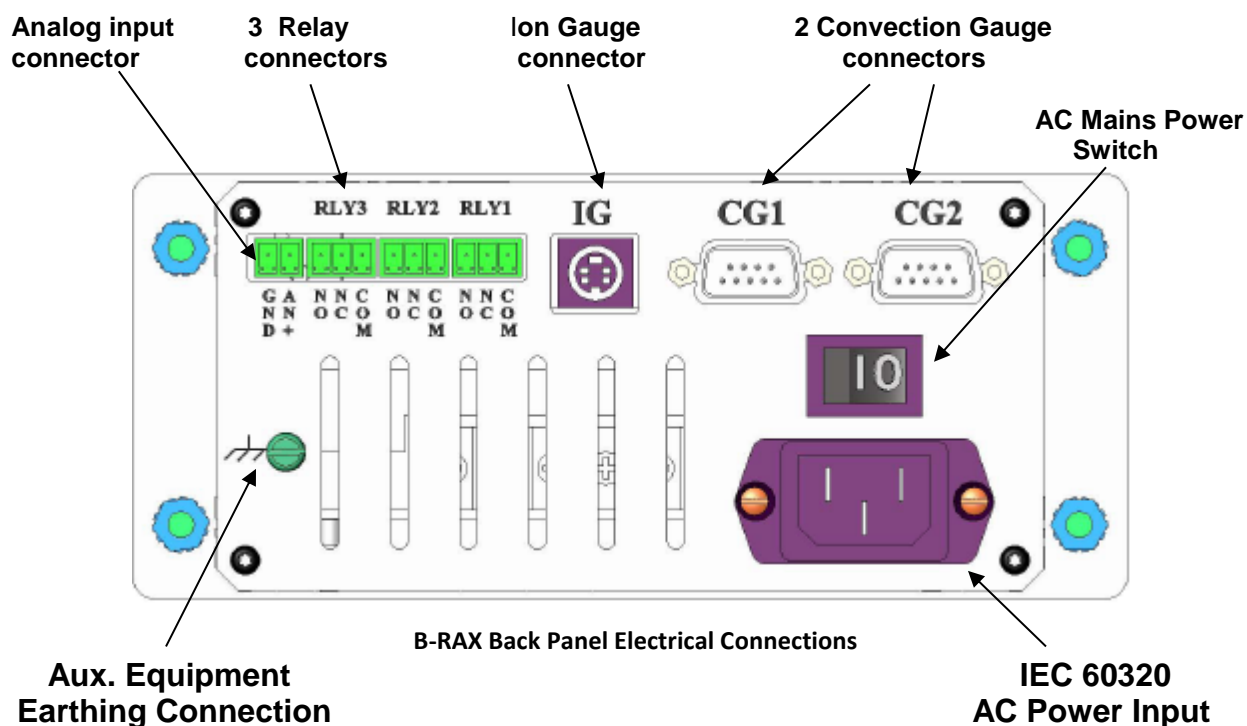

### 3.2.3 IEC 60320 AC Power Input

Universal AC power cord input connector. The B-RAX accepts AC Mains power from 100 to 240 VAC, 50/60Hz, nominal. The B-RAX controller is provided with a NEMA 5-15P power cord set with North America 115 Vac plug and mating IEC60320 plug for connection to the B-RAX AC Power Input connector. The IEC 60320 power inlet connector on the B-RAX will allow international cord sets with 100-240 Vac power plugs commonly used in other regions to be used directly. Single phase AC Mains power and protective earthing connections are provided by the IEC 60320 compatible power cord set. Set the AC Power Switch to OFF (0) before connecting power cord.

### 3.2.4 Connecting the IGM400 or CCM500 - connector labeled IG

Good, recommended practice is to remove power from any cable prior to connecting or disconnecting it. Use the cable/connector assembly provided by InstruTech for connection to the B-RAX vacuum gauge controller. The programming parameters for the IGM400 and CCM500 module are transmitted between the module and the B-RAX immediately during initial AC Mains Power ON condition. If an IGM400 or CCM500 module is swapped or a cable from one module is moved and reconnected to a different module, the B-RAX considers the first module connected at power ON to be the device it is communicating with.

Changing cables from one device to another when power is applied to the module is not only bad electronics handling procedure, it is not advised and, if done by the user of this equipment, may lead to erroneous measurement results, a hazardous situation, equipment damage and possible operator injury .

 **CAUTION!** Possible damage to property and injury to personnel may result if connections to the Ion Gauge (**IG**) connector are made while power is applied to the B-RAX control unit. **DO NOT** connect, disconnect or reconnect the cable from the B-RAX back panel **IG** connector to either the IGM400 or the CCM500 module when power is applied to the B-RAX. Switch the AC Mains Power Switch on the back panel of the B-RAX to OFF (0) prior to either disconnecting or reconnecting cables to external devices such as the IGM400 and CCM500 modules.

The DE-9 D-subminiature end of the InstruTech cable assembly for connecting the IGM400 or the CCM500 ion gauge module to the B-RAX is connected to either the IGM400 or CCM500 module. The mini-DIN connector end of this cable connects to the connector labeled **IG** on the back panel of the B-RAX



### 3.2.5 Connecting the CVG101 - connectors labeled CG1 and CG2

For your reference, the wiring chart for the CVG101 cable provided by InstruTech is provided here. Connect the DE-9 D-subminiature connector to B-RAX and CVG connectors to CG1 or CG2. In addition to InstruTech provided standard cable assembly lengths, InstruTech will provide custom length cable assemblies upon request.

B-RAX pin number (9-Pin D Sub.)	connects to ⇒	CVG gauge pin number (InstruTech molded, custom connector)
1		NC
2		cable shield
3		3
4		3
5		2
6		5
7		1
8		1
9		NC

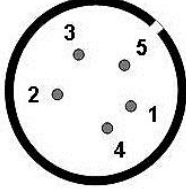

### 3.2.6 Relay Connectors

Three each 3-contact pluggable terminal strip connectors are available for easy connection to the setpoint relay contactors. The B-RAX back panel connectors are marked RLY1, RLY2 and RLY3. Each relay has a contact named COM (common), NC (normally closed) and NO (normally open).

RLY1, RLY2 and RLY3 (contacts)	Contact Description
COM	Relay #1, Relay #2 and Relay #3 COMMON
NC	Relay #1, Relay #2 and Relay #3 NORMALLY CLOSED
NO	Relay #1, Relay #2 and Relay #3 NORMALLY OPEN

### 3.2.7 Alternate gauge installation

When using a capacitance manometer/diaphragm gauge (CDG) as an ALTERNATE GAUGE, the gauge must be connected to the B-RAX as shown below. Relay #3 COMMON must be used in this configuration to protect the IG from being turned on at high pressure. As such, when using an alternate gauge, Relay #3 is no longer available for setpoint control and only Relays #1 and #2 are active. The alternate gauge must be provided power from an auxiliary power supply capable of providing the power required by the alternate gauge connected to the B-RAX.

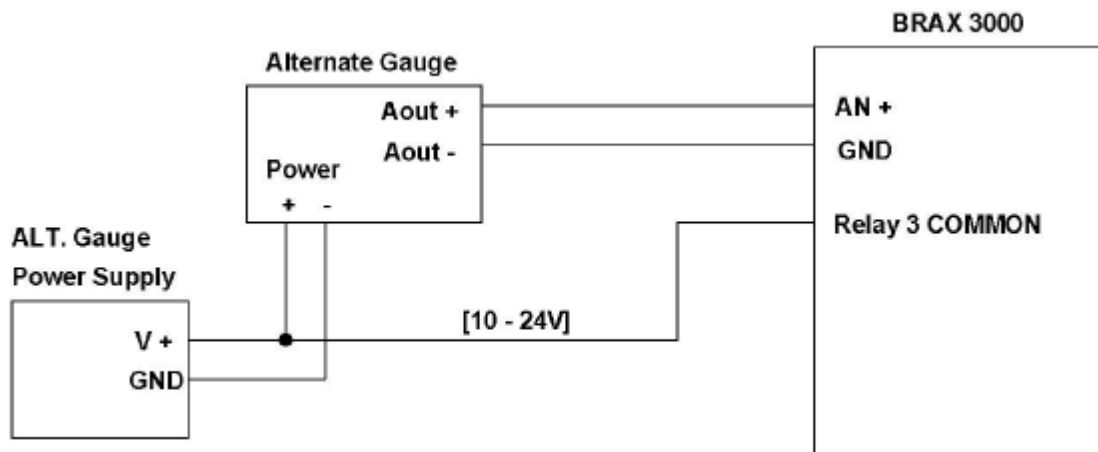

An Auxillary Power Supply is required for your Alternate Gauge, e.g., a CDG. Ensure power is applied to your Alternate Gauge before turning the B-RAX AC Power Switch to ON (1).

Using an Alternate Gauge such as a Capacitance Diaphragm Gauge with the B-RAX 3000

## 4 Setup and Operation

### 4.1 Applying power

Before you turn on power to the B-RAX for the first time, ensure the cables from the B-RAX to the IGM400 or CCM500 and CVG101 vacuum gauges are connected and secured. Connect AC mains power to B-RAX using the AC input connector. If you are using an alternate gauge such as a capacitance manometer (CDG), make sure it is connected and powered before turning on the B-RAX. Refer to [section 3.2.8](#), above, regarding connecting an alternate gauge. Turn the AC Mains Power Switch position to on (1).

### Display - Pressure Measurements

The B-RAX provides three independent front panel LED displays:

- 1) IG display represents pressure measurements from the IGM400 or CCM500 ion gauge module.
- 2) CG1 display represents pressure measurements from the first convection gauge.
- 3) CG2/ALT display represents pressure measurements from the second convection gauge, or an analog signal from another type of vacuum gauge (alternate gauge).

### Display - Pressure Measurement Engineering Units

A yellow LED is illuminated next to the selected engineering unit indicating measurements in Torr, mbar or Pa (the pascal unit of measure is written as 'PASCAL' on the front panel; mbar unit is written as mBar).

### Display - Setup Screen

The B-RAX provides an independent setup and programming LCD display screen. This screen is used for set up, programming and operation of the ion and convection vacuum gauges.

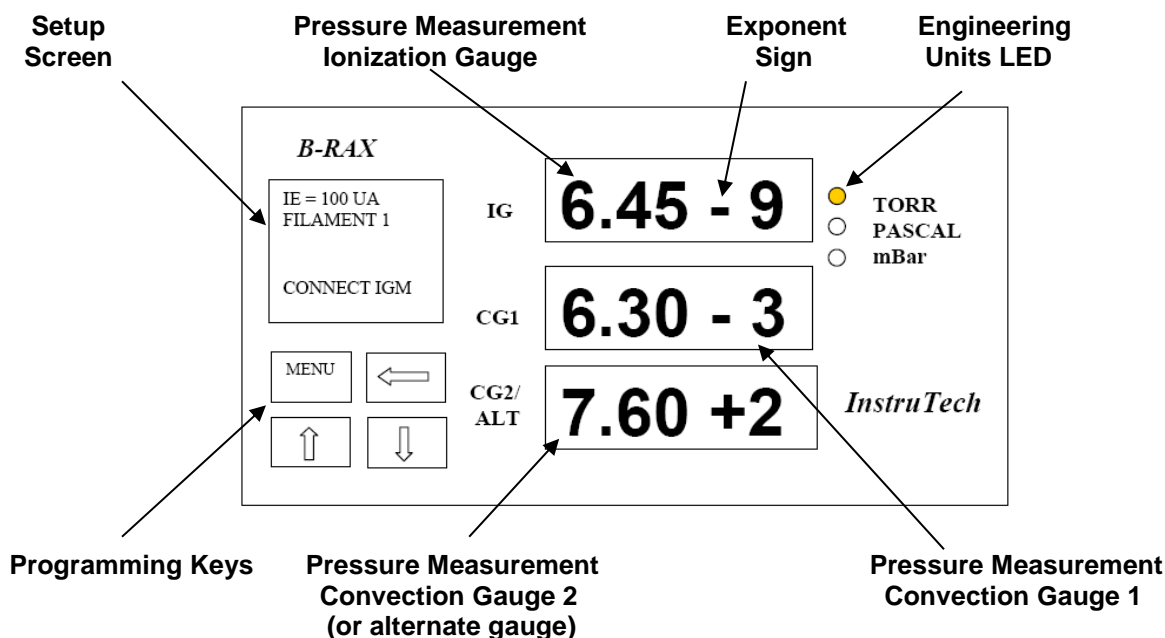

## 4.2 Emission Current - IGM400 only

4 mA and 100  $\mu$ A (0.1 mA) are available settings of emission current for the hot cathode ion gauge used in the IGM400. The concept of using a carefully controlled emission current for creating ions within the vacuum region of the transducer does not apply to the CCM500 cold cathode ion gauge technology.

- 1) In clean applications and when operating at higher pressure ranges ( $5.00 \times 10^{-6}$  Torr to  $5.00 \times 10^{-2}$  Torr) the 100  $\mu$ A emission setting is preferred.
- 2) At lower operating pressures ( $1.00 \times 10^{-9}$  Torr to  $5.00 \times 10^{-4}$  Torr) the 4 mA emission setting should be used.
- 3) When using a diffusion pump or other pumps that use fluids, there is a possibility of the pump oil vapors entering the IG transducer. These vapors may form an insulator on the internal components of the transducer which can lead to instability or failure in controlling the emission. In this case, 4 mA emission current may provide improved operating lifetime and measurement performance.
- 4) The emission current can also be set to automatically switch between 100  $\mu$ A and 4 mA. This results in optimal and stable pressure readings over the entire measurement range from low to high vacuum. For example, if an application requires that pressure measurements be performed by the ion gauge from pressures lower than  $5.00 \times 10^{-6}$  Torr up to  $5.00 \times 10^{-2}$  Torr, then the user may want to consider the AUTO IE selection. If so, select AUTO IE in the EMISSION SELECT menu and press ENTER to save the setting for this selection.

## 4.3 Degas - IGM400 only

Degas is used to rid a hot cathode ion gauge sensor of adsorbed gas. Degas is achieved by applying Electron Bombardment (EB) to the grid. The intervals at which degas should be applied vary for each application. The low pressure measurement performance of the transducer will normally improve after each degassing cycle.

- Degas can only be applied while the filament is turned on and operating.
- Ensure that the vacuum pressure is at or less than  $5.00 \times 10^{-5}$  Torr before attempting to initiate degas.
- Filament drive power during degas is about 3 watts higher than during normal pressure measurement.
- Degas will automatically turn off after 2 minutes when using factory default settings. Degas can be programmed for duration of 2 to 10 minutes.
- The IGM400 will continue to measure approximate pressure while degas is in progress.
- Degas will automatically turn off if the pressure exceeds  $3.00 \times 10^{-4}$  Torr during the degas cycle.
- Degas can be interrupted by turning the IGM400 filament off.

#### 4.4 IGM400 Filament Material Selection / Venting the Chamber

The choice of which filament to use in the IGM400 is primarily dependent upon the process and process gases the ion gauge will be used with. For general vacuum applications, dual yttria coated filaments are offered for use with air and inert gases such as N<sub>2</sub>, argon, etc. Optional dual tungsten filaments are available for use with gases that are not compatible with yttria coated iridium filaments.

##### 1) Yttria coated iridium filament

In most general vacuum applications, the yttria coated iridium filament is the best choice.

Yttria coated iridium filaments typically operate at a lower temperature than tungsten filaments and thus have a lower outgassing rate at UHV and lower chemical reactivity with active gases. Yttria coated iridium filaments typically have a longer operating life than tungsten filaments in clean applications.

The yttria coated filament can survive occasional accidental start attempts at atmosphere in air, but the overall life of the filament may be shortened during each occurrence. Good vacuum practice is to use a separate pressure gauge such as InstruTech's *Worker Bee™* convection gauge to know when to turn on the ion gauge filament.

##### 2) Tungsten filament

Typically, a bare tungsten filament is a better choice in those applications where an yttria coated filament is quickly damaged due to the gas type in use. For example, processes such as ion implantation may only use tungsten filaments. Be aware that corrosive applications are hard on any filament and filament life will be shortened while operating in such environments. Tungsten filaments are easily damaged by exposure to air/oxygen during accidental system vents or if considerable quantities of water vapor are outgassed during pump-down and bake-out. It is very important to make sure the tungsten filament is turned off before bringing the chamber up to atmosphere, especially if air is being used to vent the chamber. The use of pure N<sub>2</sub> gas is highly recommended to vent or purge your vacuum chamber. Testing has shown that tungsten filaments can withstand limited high pressure excursions when only N<sub>2</sub> is present.

Venting with air or other gases containing oxygen can damage the tungsten filaments. If you try to turn on an ion gauge with tungsten filaments while it is sitting on your desk exposed to room air, you will immediately damage or destroy the filament beyond repair.

**NOTICE**

Do not use another gauge to automatically turn off the ion gauge when the ion gauge (IG) filament in use is constructed of tungsten (yttria coated filament is ok). The response time of other gauges may not allow for timely turn off of the tungsten filament leading to filament damage. Always turn off the IG filament manually before pressure is allowed to rise above  $1.00 \times 10^{-3}$  Torr.

**Note** - Both types of filaments will suffer eventual damage if operated at high pressures. The type and amount of damage at high pressure is dependent upon the length of operating time, the pressure and the gas present.

#### 4.5 Overpressure shut down - IGM400 and CCM500

The IGM400 is provided with factory set default values for overpressure shut down. The gauge will shut off automatically should the pressure reach or rise above the pressure shut down values shown below:

**Factory set IGM400 overpressure shut down values**

Emission Current	Overpressure Shut Down (Torr)	Overpressure Shut Down (mbar)	Overpressure Shut Down (Pa)
4 mA	$1.00 \times 10^{-3}$	$1.33 \times 10^{-3}$	$1.33 \times 10^{-1}$
100 $\mu$ A (0.1 mA)	$5.00 \times 10^{-2}$	$6.66 \times 10^{-2}$	6.66

The CCM500 is provided with factory set default values for overpressure shut down. The gauge will shut off automatically should the pressure reach or rise above the pressure shut down values shown below:





**Factory set CCM500 overpressure shut down values**

Overpressure Shut Down (Torr)	Overpressure Shut Down (mbar)	Overpressure Shut Down (Pa)
$1.00 \times 10^{-2}$	$1.33 \times 10^{-2}$	1.33

The information presented in sections 4.2 through 4.5, above, is included here as an introduction to the programming capabilities of the B-RAX 3000 for use in controlling the selectable parameters and functions of the IGM400 and CCM500 devices. Refer to the User Manual for the connected device for complete operation and setup instruction.

#### 4.6 User Interface Basics

The setup and programming of the B-RAX controller is done via the four [programming-keys](#) located below the LCD setup screen on the left hand side of the B-RAX front panel. During programming of the B-RAX, the LCD display will identify what function each key represents.

To begin programming, press the MENU key. Press the UP and DOWN key to select the desired menu and change the parameters. Press the ENTER key {this is the  key with the arrow pointing to the left as viewed from the front of the B-RAX} to access the parameters and save the new settings. Press the  Key to return to the previous menu or press repeatedly to return to the main screen. To continue setting additional parameters, scroll with the UP {} and DOWN {} keys until you reach the desired parameter then press ENTER.

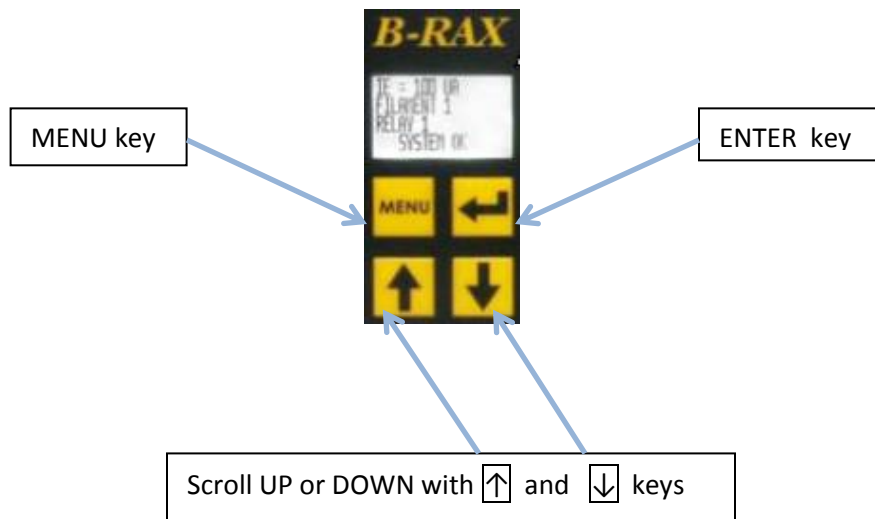

## 4.7 Factory-Set Default Parameters

The following is a summary of all factory-set default values in the B-RAX LCD display menu.

### **SETUP IG - using the IGM400 (hot cathode ion gauge module)**

- IG UNIT ON/OFF [Factory default = OFF]
- DEGAS ON/OFF [Factory default = OFF]
- EMISSION SELECT [Factory default = IE = 100UA]
- AUTO IE TRIP [Factory default = DISABLED]
- SELECT FILAMENT [Factory default = FILAMENT 1]
- DEGAS TIME [Factory default = 2 MINUTES]
- GAS TYPE [Factory default = GAS = N2]
- SENSITIVITY [Factory default = 10]
- OVER PRES 100 [Factory default = 5.00E-02]
- IG TRIP PRESSURE [Factory default = 1.00E-03]
- IG CONTROL [Factory default = MANUAL MODE]

### **SETUP IG - using the CCM500 (cold cathode ion gauge module)**

- IG UNIT ON/OFF [Factory default = OFF]
- HV TIMEOUT [Factory default = 10 minutes]
- GAS TYPE [Factory default = GAS = N2]
- SENSITIVITY [Factory default = 10]
- OVER PRESSURE [Factory default = 1.00E-02]
- IG TRIP PRESSURE [Factory default = 1.00E-03]
- IG CONTROL [Factory default = MANUAL MODE]
- CAL FACTORS [Factory default = 10]

### **SETUP CG**

- SET CG2/ALT [Factory default = CG2]
- SET VAC CG1 [Factory default = PRESS ENTER TO SET VAC]
- SET ATM CG1 [Factory default = 7.60E+02 TORR]
- SET VAC CG2 [Factory default = PRESS ENTER TO SET VAC]
- SET ATM CG2 [Factory default = 7.60E+02 TORR]

### **SETUP UNIT**

- UNITS [Factory default = TORR]
- CONTRAST [Factory default = 6]
- RELAY 1 LO TRIP [Factory default = 1.00E-06 TORR]
- RELAY 1 HI TRIP [Factory default = 2.00E-06 TORR]
- RELAY 2 LO TRIP [Factory default = 1.00E-01 TORR]
- RELAY 2 HI TRIP [Factory default = 2.00E-01 TORR]
- RELAY 3 LO TRIP [Factory default = 1.00E-01 TORR]
- RELAY 3 HI TRIP [Factory default = 2.00E-01 TORR]
- ASSIGN RELAY 1 [Factory default = ION GAUGE]
- ASSIGN RELAY 2 [Factory default = CG1]
- ASSIGN RELAY 3 [Factory default = CG2]
- ALTERNATE GAUGE [Factory default = 10 Torr CDG]
- INFO [Factory default = FIRMWARE VERSION]
- DEFAULTS [Factory default = PRESS ENTER TO SET OR MENU TO EXIT]



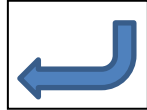

## 4.8 Programming

This section provides detailed information on programming and configuration of various menus and submenus of the device.



← This key, on the B-RAX front panel, is referred to as the 'ENTER' key throughout this manual.

From the main menu (press the **MENU** key if the main menu is not shown), scroll Up  or Down  to **SETUP IG** then press the ENTER key to access the SETUP IG menu for configuring the IGM400 ionization gauge. In certain instances, during setup of the programmed functions and settings, you may need to press the ENTER key until you reach the end of a program/setup sequence before pressing the **MENU** key to return to the main menu or previous setup screen.

### 4.8.1 SETUP IG - IGM400

- **IG UNIT ON/OFF** [Factory default = OFF]

Use the Up and Down keys and select ON to turn the filament on or OFF to turn the filament off. Press ENTER to save setting. Press the DOWN key to move down to the next menu selection.

**NOTICE** Before you activate the ion gauge/filament, make sure you understand all instructions and information provided in this manual and the User Manual for the IGM400. Furthermore, you should ensure you have fully configured the B-RAX control unit to your operational requirements before turning the filaments on. Prior to turning on the filament you should ensure the pressure is below the OVERPRESS 100 setting if the emission current selection is set to 100  $\mu\text{A}$  or below the  $1.00 \times 10^{-3}$  Torr if emission current selected is 4 mA.

**CAUTION!** You must be aware of possible risks of inadvertently starting emission (turning the IG filament on) when using an alternate gauge like a capacitance diaphragm gauge as a source of control for turning the ion gauge on and off. Failure to do so may cause damage to the gauge and other equipment in your system.

**CAUTION!** Due to the risk of filament failure caused by inadvertent exposure to oxidizing gases or gas mixtures, never use another gauge to automatically turn off the ion gauge when the ion gauge filament in use is constructed of tungsten (yttria coated iridium filament is okay). The response time of other gauges may not allow for timely turn off of the filament leading to filament damage especially for tungsten filaments. Always turn the IG filament OFF manually before pressure is allowed to rise above 1.00E-03 Torr.

- **DEGAS ON/OFF** [Factory default = OFF]

Press ENTER to access the **DEGAS ON/OFF** setting. Use the Up and Down keys to select **DEGAS ON** then press ENTER to start degas. Press the DOWN key to move down to the next menu selection.

- **EMISSION SELECT** [Factory default = IE = 100UA]

Use the Up and Down key to select emission current to 4 mA, 100  $\mu$ A, or AUTO IE. Then press ENTER to save setting.

- **AUTO IE TRIP** [Factory default = DISABLED]

The default setting is *DISABLED* if EMISSION SELECT menu above is set to 4 mA or 100  $\mu$ A. If the EMISSION SELECT menu is set to AUTO IE, then the AUTO IE TRIP value allows the user to select the pressure at which automatic switching of the emission current takes place. The user has the choice of programming the AUTO IE TRIP point anywhere between 1.00E-06 to 1.00E-04 Torr.

For example, if the AUTO IE TRIP point is set to 1.00E-05 Torr, then the ion gauge will operate at a emission current of 100  $\mu$ A over a pressure range of 5.00E-02 to 1.00E-05 Torr. The emission current will then automatically switch to 4 mA for the lower pressure range of 1.00E-05 to 1.00E-09 Torr.

- **SELECT FILAMENT** [Factory default = FILAMENT 1]

Allows user to select which filament to operate: either *Filament 1* or *Filament 2*.

**NOTICE** It is highly recommended to periodically alternate operating filaments 1 and 2 if the filaments are the coated iridium type. An inactive, coated filament not operated for an extended period of time can cause failure of that filament to establish and maintain emission current. This will become more problematic in applications where the filament coating may become poisoned by process gas byproducts or materials that have outgassed from the process materials.

- **DEGAS TIME** [Factory default = 2 MINUTES]

The length of time, in minutes, degassing will run after it is initiated. The degas cycle can be selected from 2 to 10 minutes in duration.

- **GAS TYPE** [Factory default = GAS = N2]

**GAS TYPE is applicable to the Ion Gauge only** - use the UP and DOWN Keys to choose a specific gas type from a table of 16 commonly used gases. The IG pressure reading will be a direct, true pressure reading when the gas type that is selected is the type of gas in your vacuum vessel. Gas type choices are:  $N_2$ , Air,  $O_2$ , CO,  $H_2O$ , NO, Ar,  $CO_2$ , Kr,  $SF_6$ , Xe, Hg, He, Ne,  $D_2$ , and  $H_2$ .

**CAUTION!** If you intend to use nitrogen as the default gas setting even though the gas in use is not nitrogen, you can select  $N_2$  from the menu, but you must manually apply a gas sensitivity correction factor to the displayed measurement and outputs (Refer to [section 5](#) titled "Using the gauge with different gases").

- **SENSITIVITY** [Factory default = 10]

All InstruTech ion gauge transducers (sensors) are marked with their unique, specific sensitivity value. The user must program the actual transducer (sensor) sensitivity in this menu. The actual sensitivity value of the IGM400 sensor is marked on the sensor mounting plate below the electronic enclosure. The sensitivity value is designated with the letter "S" and it is a number that normally ranges between 8 and 15. Ion gauge pressure readings are calibrated for nitrogen. If you use a different species of gas or mixture of gases other than the 16 gases listed under the GAS TYPE submenu of the SETUP IG menu, you will be required to either make manual corrections to the pressure readout or compensate the reading. The sensitivity adjustment

function of the IGM400 you are using to measure the pressure of a gas other than nitrogen/air may be set to compensate the reading. Compensating the pressure reading using the sensitivity adjustment method may not be possible for certain gases if the sensitivity correction factor results in a calculated sensitivity outside the adjustment range.

**⚠ CAUTION!** The user assumes all risks if the IGM400 *SENSITIVITY* is programmed to a value not matching the actual transducer (sensor) sensitivity marked on the sensor mounting plate below the electronic enclosure. Failure to ensure that the B-RAX is programmed for the actual sensitivity of the transducer it is used with may result in pressure readings that are not true pressure. Equipment damage due to incorrect pressure readings and improper system control functions as a result of incorrect pressure measurement readings may result.

- **OVER PRES 100** [Factory default =  $5.00E-02$ ]

This function allows the user to set the pressure at which the gauge will turn off when the emission current is running at 100  $\mu$ A.

The overpressure shut down values are adjustable when emission current selected is 100  $\mu$ A. However, the overpressure shut down value is factory set to  $1.00E-03$  when emission current selected is 4 mA and cannot be changed by the user.

- **IG TRIP PRESSURE** [Factory default =  $1.00E-03$ ]

This setting allows the user to select a pressure value at which the CG1, CG2 or the alternate gauge can turn on the IG. This is applicable only when the gauge is operating at 100  $\mu$ A emission current setting or in the automatic emission current switching mode (*EMISSION SELECT = AUTO IE*) and the IG CONTROL mode below is set to *CG1*, *CG2*, or *ALTERNATE GAUGE*.

The *IG TRIP PRESSURE* value can never be set higher than  $5.00E-02$  TORR when operating in the 100  $\mu$ A emission current setting.

The user does not have the choice to select a turn on point for the IG when 4 mA emission current has been selected. The IG turn on and off is always set to  $1.00E-03$  Torr when the emission current is set for 4 mA.

- **IG CONTROL** [Factory default = *MANUAL MODE*]

This function allows the user to choose the source of control for the IG. The IG can be controlled from the Front Panel (*MANUAL MODE*), a Convection Gauge (*CG1*, *CG2*) or *ALTERNATE GAUGE*.

Select *MANUAL MODE* if you wish to use the front panel programming keys to turn the ion gauge transducer filament to the on or off state.

Select *CG1*, *CG2*, or *ALTERNATE GAUGE* if the pressure measurement from *CG1*, *CG2*, or *ALTERNATE GAUGE* is to be used to automatically turn the ion gauge transducer filament on and off.

**CAUTION!** Never use another gauge to automatically turn off the ion gauge when the ion gauge filament in use is constructed of tungsten material (a coated filament such as the yttria coated iridium version is okay). The response time of other gauges may not allow for timely turn off of the tungsten filament

**leading to possible filament damage. Always turn the IG filament OFF manually before pressure is allowed to rise above 1.00E-03 Torr.**

When either *CG1*, *CG2*, or *ALTERNATE GAUGE* is selected in the IG CONTROL menu and the ion gauge emission current is set to 100  $\mu$ A, the ion gauge filament will turn on when the pressure measured by *CG1*, *CG2*, or *ALTERNATE GAUGE* drops below the value programmed in the IG TRIP PRESSURE. The ion gauge filament will turn off when the pressure measured by *CG1*, *CG2*, or *ALTERNATE GAUGE* rises above the value programmed in the *IG TRIP PRESSURE* setup screen.

If the ion gauge emission current is set to 4 mA, the ion gauge filament will turn on when the pressure measured by *CG1*, *CG2*, or *ALTERNATE GAUGE* drops below 1.00E-03 Torr. The ion gauge filament will turn off when the pressure measured by *CG1*, *CG2*, or *ALTERNATE GAUGE* rises above 1.00E-03 Torr.

When *CG1*, *CG2*, or *ALTERNATE GAUGE* is selected in the IG CONTROL setup screen, the user will not be able to turn off or turn on the IG filament manually. In this case, the *IG UNIT ON/OFF* selection of the *SETUP IG* function will be displayed as *DISABLED*. Consider the following two approaches if you want to turn off or turn on the ion gauge filament and override the control from *CG1*, *CG2* or *ALTERNATE GAUGE*.

- 1) Go to the *IG CONTROL* selection of the *SETUP IG* menu and change the setting to *MANUAL MODE*. Next, go to the *IG UNIT ON/OFF* selection of the *SETUP IG* menu and change the setting to *OFF*. This will send the off command to the ion gauge and will turn the ion gauge filament off. Once you are ready to re-assign *CG1*, *CG2*, or *ALTERNATE GAUGE* to control the IG, go back to *IG CONTROL* selection of the *SETUP IG* menu and change the setting back to *CG1*, *CG2*, or *ALTERNATE GAUGE*.
- 2) The second approach of overriding the controls from *CG1*, *CG2* or *ALTERNATE GAUGE* is to simply remove AC Mains power from B-RAX.

**⚠ CAUTION!** You must be aware of possible risks of inadvertently starting emission (turning the IG filament to ON) when using an alternate gauge like a capacitance diaphragm gauge as a source of control for turning the ion gauge on and off. Failure to follow the recommended procedures for ensuring that you do not inadvertently allow the ion gauge transducer filament to turn on may result in equipment damage.

To minimize the risk associated with this using an alternate gauge to control the ion gauge transducer filament, follow these recommended steps below precisely:

- 1) Before selecting *ALTERNATE GAUGE* in the *IG CONTROL* menu, the user should turn off power to the B-RAX.
- 2) Connect the alternate gauge to the B-RAX.
- 3) Apply power to the alternate gauge.
- 4) Next apply power to the B-RAX.
- 5) Select *ALTERNATE GAUGE* in the *IG CONTROL* menu.

Cables should never be hot-swapped on the B-RAX (or any other InstruTech device). Failure to follow the steps above may result in damage to the gauge and other equipment in your system.

#### 4.8.2 SETUP IG - CCM500

If you are familiar with operating the B-RAX with the IGM400 connected as described in [Section 4.8.1](#) above, you will find the operation and setup when connecting the B-RAX to the CCM500 is very similar with a few exceptions.

Press the ENTER Key to access the SETUP IG menu for configuring the CCM500 ionization gauge module.

- **IG UNIT ON/OFF** [Factory default = OFF]

Use the Up and Down keys and select ON to turn the CCM500 cold cathode ion gauge (CCIG) on; or OFF to turn the device off. Press ENTER to save setting. Press the DOWN key to move down to the next menu selection.

- **HV TIMEOUT** [Factory default = 10 minutes]

Enter this menu choice to program the maximum wait period after the CCIG ON command is invoked and the CCM500 starts to read pressure. This time period can be set from 1 to 60 minutes. Default setting is 10 minutes. Press the DOWN key to move down to the next menu selection.

The cold cathode gauge will exhibit some level of activation time delay when the sensor is being activated at pressures below 1.0E-5 Torr. This is the time needed for the electrical discharge to establish itself at low pressures. A rough estimate for this time delay can be determined by the following equation:

$$T, \text{ seconds} = 1/\text{pressure } \mu\text{Torr}$$

Example: If the pressure at which the gauge is being activated is 1.0E-7 Torr (10E-2  $\mu$ Torr), then  $T = 1 / 0.01$  indicating that it may roughly take at least 100 seconds or more for the sensor to turn on.

The HV TIMEOUT is the time allowed for the gauge to activate during which time the unit will attempt repeatedly to turn on the anode voltage. If the gauge has not been activated after this time has elapsed, the unit will stop attempting to turn on the anode voltage and the user will be prompted with "DISCHARGE FAIL" or "CURRENT FAIL" error messages. If this is the case, the user must clear the error and repeat the process of turning on the anode voltage again.

- **GAS TYPE** [Factory default = GAS = N2]

The selection of *GAS TYPE* is the same for the CCM500 as it is for the IGM400. Refer to the entire section regarding [GAS TYPE for the IGM400](#) above, for important information regarding the use of the *GAS TYPE* function.

- **SENSITIVITY** [Factory default = 10]

Factory pre-set sensitivity for the CCM500 is always 10 and maybe adjusted by the user if necessary. Ion gauge pressure readings are calibrated for nitrogen. If you use a different species of gas or mixture of gases other than the 16 gases listed under the GAS TYPE submenu of the SETUP UNIT menu, you will be required to either make manual corrections to the pressure readout or compensate the reading. The sensitivity adjustment function of the CCM500 you are using to measure the pressure of a gas other than nitrogen/air may be set to compensate the reading. Compensating the pressure reading using the sensitivity adjustment method may not be possible for certain gases if the sensitivity correction factor results in a calculated sensitivity outside the adjustment range.

**User assumes all risks if sensitivity is set to a value different than the factory default setting of 10.**

- **OVER PRESSURE** [Factory default =  $1.00E-02$ ]

This function allows the user to set the pressure at which the gauge will turn off when the vacuum vessel pressure rises above this setting. The overpressure shut down values are adjustable - set this value to a pressure level that is acceptable for your application. Operating any ion gauge at too high a pressure in the presence of certain gases and gas mixtures may result in significant sputtering action of the internal electrodes of the transducer (sensor) leading to changes in performance of the device.

- **IG TRIP PRESSURE** [Factory default =  $1.00E-03$ ]

This setting allows the user to select a pressure value at which the CG1, CG2 or the alternate gauge can turn the CCIG on. The *IG TRIP PRESSURE* value for the CCM500 can never be set higher than  $1.00E-02$  TORR.

- **IG CONTROL** [Factory default = *MANUAL MODE*]

This function allows the user to choose the source of control for the IG. The IG can be controlled from the Front Panel (*MANUAL MODE*), or Convection Gauge *CG1*, *CG2*, or *ALTERNATE GAUGE*.

Select *MANUAL MODE* if you wish to use the front panel programming keys to turn the ion gauge transducer to the on or off state.

Select *CG1*, *CG2*, or *ALTERNATE GAUGE* if the pressure measurement from *CG1*, *CG2*, or *ALTERNATE GAUGE* is to be used to automatically turn the ion gauge transducer on and off.

- **CAL FACTORS** [Factory default = 10]

There are six sensor calibration factor constants referred to as CAL FACTORS C that are established during factory calibration. These values are also physically marked on the sensor mounting plate below the electronics enclosure. The six calibration factors are designated C0, C1, C2, C3, C4, and C5 and are used to characterize the sensor response over the pressure measurement range of the device. This results in enhanced and optimum performance over the entire measurement range. User should ensure that values physically marked on the instrument match the CAL FACTORS C programmed in the B-RAX. Use care in setting these values to other than the default value - the values can be set from 1 to 99.

### 4.8.3 SETUP CG

This programming menu allows the user to set the atmospheric pressure reading (also known as the “span” adjustment) and vacuum reading (“zero” point) for the convection gauges CG1 and CG2. InstruTech advises that you **first** determine if the ‘span’ (ATM) adjustment of your measurement device is set properly **before** setting the ‘zero’ (VAC) adjustment. It is good practice to perform the sequence of checking and adjusting ATM (span) then VAC (zero) and then, finally re-checking the ATM setting to ensure that the circuitry is properly balanced for use in measuring pressure throughout the intended measurement range.

Press the ENTER key to access the *SETUP CG* menu for configuring the convection gauges or other types of alternate gauges using the analog input port.

- **SET CG2/ALT** [Factory default = CG2]

This control function allows the user to select the type of gauge used for the third display labeled CG2/ALT.

Select CG2 if the third gauge used is a convection gauge. This can be either the InstruTech CVG101 *Worker Bee* or Granville-Phillips Convectron® convection vacuum gauge transducer.

Select *ANALOG INPUT* if the third display line (CG2/ALT) is another type of vacuum gauge with a compatible analog output signal. This will also require setup of the *ALTERNATE GAUGE* submenu in the *SETUP UNIT* menu described in the [section 4.8.4](#) of this manual. If *ANALOG INPUT* is selected, the *SET VAC CG2* and *SET ATM CG2* will not be displayed in the menu choices listed below.

- **SET VAC CG1** [Factory default = *PRESS ENTER TO SET VAC*]

If you are using mbar or pascal units of measure, **DO NOT** perform this setting / adjustment first. Perform the SET ATM CG1 (atmosphere or span adjustment) **before** making the SET VAC CG1 adjustment.

- Press the ENTER key to access *SET VAC CG1*.
- Evacuate the system in which CG1 is installed to a pressure less than 0.1 mTorr.
- Press ENTER to set vacuum (zero).

**NOTICE** When operating with Engineering Units of mbar or pascals selected, you must first set the atmosphere indication or span adjustment (see *SET ATM* listed below). Then return to the *SET VAC* menu and set the vacuum or zero reading. Failure to set the atmosphere reading first (before you *SET VAC*) will result in an incorrect setup of the gauge. If you change units or reset to factory defaults, then the same procedure must be followed again if the units of measure is being set to mbar or Pa.

- **SET ATM CG1** [Factory default = *7.60E+2 TORR*]

Press the ENTER key to access the *SET ATM CG1* screen.

Backfill the vacuum vessel /chamber with nitrogen gas to a known pressure between 400 Torr and 1000 Torr. Alternatively, if your local uncorrected barometric pressure (air) is known, simply vent your vacuum system chamber to expose the gauge to the local atmospheric pressure. When desired system pressure is stable, adjust the pressure on the screen to the known value using the UP or DOWN keys. Press the ENTER key to move to the next digit and use the UP or DOWN keys to decrease or increase the value of that digit. Continue pressing the ENTER key until the SET ATM CG1 reappears on the display. The new atmosphere point is now set.

- **SET VAC CG2** [Factory default = *PRESS ENTER TO SET VAC*]

Same as *SET VAC CG1* above, except select CG2.

See the **NOTICE** above when operating in units of mbar or pascals - you must first set the atmosphere or span adjustment.

- **SET ATM CG2** [Factory default = *7.60E+2 TORR*]

Same as SET ATM CG1 above, except select CG2.

#### 4.8.4 SETUP UNIT

Press the ENTER key to access the *SETUP UNIT* menu for configuring the display, engineering units, assigning relays, etc.

- **UNITS** [Factory default = *TORR*]

This allows the user to display the pressure measurements in Torr, mbar or pascal. The user must program all other programming values according to their requirements.

- **CONTRAST** [Factory default = 6]

This allows the user to adjust the LCD display contrast.

- **RELAY 1 LO TRIP** [Factory default =  $1.00E-01$  *TORR*]

This setpoint corresponds to the turn on points for Relay #1. Relay #1 will turn on when the pressure drops below this setting.

- **RELAY 1 HI TRIP** [Factory default =  $2.00E-01$  *TORR*]

This setpoint corresponds to the turn off points for Relay #1. Relay #1 will turn off when the pressure rises above this setting.

- **RELAY 2 LO TRIP** [Factory default =  $1.00E-01$  *TORR*]

This setpoint corresponds to the turn on points for Relay #2. Relay #2 will turn on when the pressure drops below this setting.

- **RELAY 2 HI TRIP** [Factory default =  $2.00E-01$  *TORR*]

This setpoint corresponds to the turn off points for Relay #2. Relay #2 will turn off when the pressure rises above this setting.

- **RELAY 3 LO TRIP** [Factory default =  $1.00E-01$  *TORR*]

This setpoint corresponds to the turn on points for Relay #3. Relay #3 will turn on when the pressure drops below this setting.

- **RELAY 3 HI TRIP** [Factory default =  $2.00E-01$  *TORR*]

This setpoint corresponds to the turn off points for Relay #3. Relay #3 will turn off when the pressure rises above this setting.

- **ASSIGN RELAY 1** [Factory default = *ION GAUGE*]

This assigns Relay #1 to the ion gauge, CG1 or CG2.

- **ASSIGN RELAY 2** [Factory default = *CG1*]

This assigns Relay #2 to the ion gauge, CG1 or CG2.

- **ASSIGN RELAY 3** [Factory default = *CG2*]

This assigns Relay #3 to the ion gauge, CG1 or CG2.



**- ALTERNATE GAUGE** [Factory default = 10 Torr CDG]

This allows the use of an alternate gauge as an analog input from other types of vacuum gauges instead of the second convection gauge CG2.

- Select *100 mTorr CDG* for a 100mTorr Capacitance Diaphragm Gauge (CDG) with 0-10 Vdc analog output.
- Select *1 Torr CDG* for a 1 Torr Capacitance Manometer/Diaphragm gauge with 0-10 Vdc analog output.
- Select *10 Torr CDG* for a 10 Torr Capacitance Manometer/Diaphragm gauge with 0-10 Vdc analog output.
- Select *100 Torr CDG* for a 100 Torr Capacitance Manometer/Diaphragm gauge with 0-10 Vdc analog output.
- Select *1000 Torr CDG* for a 1000 Torr Capacitance Manometer/Diaphragm gauge with 0-10 Vdc analog output.
- Select *ITI LOG-CG* if you are using InstruTech's convection gauge modules such as the CVM-211 Stinger or CVM-201 Super Bee with a Log-linear analog output.
- Select *ITI LOG-IG* if you are using InstruTech's ionization gauge module such as the IGM-401 Hornet with a Log-linear analog output.
- Select *ITI NON-LINEAR* if you are using InstruTech's convection gauge modules such as the CVM211 Stinger or CVM201 Super Bee with the a non-linear analog output.

**NOTICE** - When using a Capacitance Manometer/Diaphragm Gauge (CDG) as an ALTERNATE GAUGE, the CDG must be properly zeroed to read correctly. The minimum pressure displayed by B-RAX will be based on a 10 mV input voltage. Users requiring better accuracy are advised to use a separate, accurate voltmeter to set the CDG zero adjustment below 10 mV and then connect the device to your B-RAX.

**- INFO** [Factory default = *FIRMWARE VERSION*]

Provides firmware version number.

**- DEFAULTS** [Factory default = *PRESS ENTER TO SET OR MENU TO EXIT*]

The system can be returned to the original factory settings by using the ENTER Key to set factory defaults. You must re-enter the actual sensor sensitivity value marked on the IGM400 sensor or the six CAL FACTORS marked on the CCM500 sensor . Ensure CCM500 sensitivity value is set to 10. The IGM400 filament or the CCM500 high voltage must be off (sensors off) in order to reset defaults.

## 5 Using the Gauge with different gases

The following tables and explanation contain important information regarding the use of ionization and convection gauges when used to measure pressure of gases other than nitrogen /air. For both types of gauge transducers, corrections must be applied to both the display and analog outputs. This is particularly critical when using convection gauges to measure gases other than N<sub>2</sub>/air.

### 5.1 Ion gauge display correction factors for selected gases

There are two methods that can be used for monitoring the IG display when using gases other than nitrogen/air:

1) Select the actual gas from the menu by selecting one of the of 16 gas choices in the *GAS TYPE* selection of the *SETUP IG* menu. In this case, the correction factor will be automatically applied to the IG display only. **The user must ensure all operators are aware the display measurement represents the true measurement value specific to the selected gas.**

Selecting gases other than N<sub>2</sub> from the programming menu applies to the ion gauge only. When using convection gauges to measure gases other than nitrogen/air, you must always apply manual correction factors to the convection gauge displays (see correction factors for the convection gauges in the following sections).

2) If you are using a gas other than N<sub>2</sub> but have selected N<sub>2</sub> as the *GAS TYPE*, you must manually apply a gas sensitivity correction factor to the IG displayed measurement. Post a label on your ion gauge display showing the correction factor to be used for the pressure of the gas type you are measuring . Table below, provides typical correction factors for ion gauges when used with gas types other than N<sub>2</sub>. To correct the display measurements, divide the displayed measured pressure by the correction factor for the gas type you are measuring:

**Ion Gauge Gas Sensitivity Correction Factors for selected gases**

Gas	Sensitivity Correction Factor
He	0.18
Ne	0.30
D <sub>2</sub>	0.35
H <sub>2</sub>	0.46
N <sub>2</sub>	1.00
Air	1.00
O <sub>2</sub>	1.01
CO	1.05

Gas	Sensitivity Correction Factor
H <sub>2</sub> O	1.12
NO	1.16
Ar	1.29
CO <sub>2</sub>	1.42
Kr	1.94
SF <sub>6</sub>	2.50
Xe	2.87
Hg	3.64

For example, if the gas in use is argon (Ar) and the ion gauge measured pressure is displayed as  $4.00 \times 10^{-7}$  Torr, the actual, true pressure of argon is then determined by the following equation:

$$\frac{4.00 \times 10^{-7}}{1.29} \text{ Torr} = 3.10 \times 10^{-7} \text{ Torr, Ar}$$

Alternatively, you may correct the display for a direct reading of pressure for the type of gas you are using by adjusting the sensitivity factor for the IG. If you adjust the sensitivity factor for your ion gauge to compensate the readout of pressure for a gas type other than nitrogen, the displayed pressure readout for that device must be annotated to indicate that the displayed pressure is for the gas type the readout is compensated for.

Ion Gauge pressure readings are calibrated for nitrogen. If you use a different species of gas or mixture of gases, you will be required to either make manual corrections to the pressure readout or compensate the reading. The sensitivity adjustment function of the *IGM400* or *CCM500* you are using to measure the pressure of gas other than nitrogen/air may be set to compensate the reading. Compensating the pressure reading using the sensitivity adjustment method may not be possible for certain gases if the sensitivity correction factor results in a calculated sensitivity outside the adjustment range possible.

In the above example, if the N<sub>2</sub> sensitivity of the ion gauge being used is 10 torr<sup>-1</sup> ("10 per torr"), the sensitivity factor programmed during setup of the B-RAX and IGM400 or CCM500 could be set for 12.9 (~13) so that the pressure readout would directly indicate the true pressure of argon. Again, the display line for that particular device pressure readout would require annotation (a user applied label) so as to not conflict with the gas type selection/notation of nitrogen (N<sub>2</sub>).

## 5.2 Effects of different gases on convection gauge display

Convection gauge operation is based on the physical effect of thermal conductivity of the gas inside the gauge transducer. The convection gauge senses heat loss in a sensor wire. This heat loss depends on the thermal conductivity of the gas surrounding the sensor wire. Since different gases, and mixtures, have different thermal conductivities, the indicated pressure readings and outputs will also be different. InstruTech convection gauges (and most other thermal, heat loss type gauges) are normally calibrated using nitrogen. When a gas other than N<sub>2</sub> is used, correction must be made for the difference in thermal conductivity between N<sub>2</sub> and the gas in use. The charts and tables below indicate how different gases affect the display from an InstruTech convection gauge.

For nitrogen gas (N<sub>2</sub>) the calibration of the convection gauge shows excellent agreement between indicated and true pressure throughout the range from 10<sup>-4</sup> to 1000 Torr. At pressures below about 1 torr, the calibration curves for the different gases are similar. The difference in readings (between indicated and true pressure) at these low pressures is usually a constant; a function of the difference between thermal conductivities of the gases.

At pressures above about 1 torr, indicated pressure readings may diverge significantly from true pressure. At these higher pressures, convection currents in the gauge become the predominant cause of heat loss from the sensor. Calibration and performance at pressures higher than about 1 torr depends on gauge tube geometry and mounting orientation as well as gas properties.

Generally, air and N<sub>2</sub> are considered the same as far as thermal conductivity goes, but even these two gases will exhibit slight differences in readings at higher pressures. For example, when venting a system to atmosphere using N<sub>2</sub>, you may see readings change by about 30 to 40 torr after the chamber is opened and air gradually displaces the N<sub>2</sub> in the gauge. This is due to the partial pressure of oxygen (O<sub>2</sub>) contained in atmospheric air.

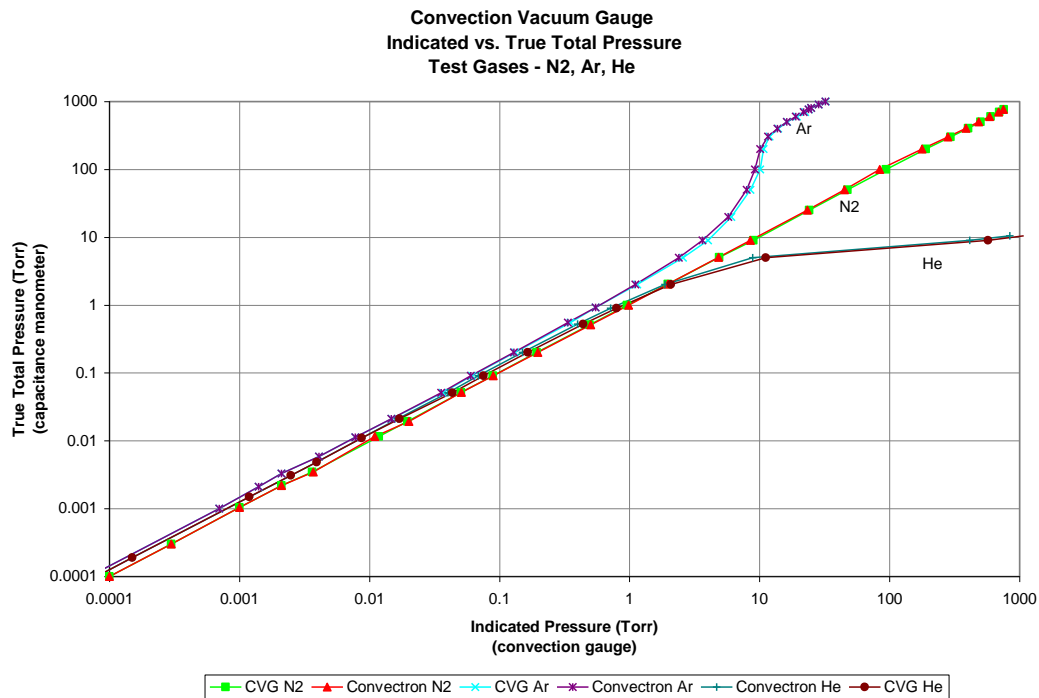

The Y- axis of the above chart is actual pressure as measured by a capacitance manometer, a diaphragm gauge that measures true total pressure independent of gas composition. The X-axis is the pressure reading indicated by the convection gauge under test. This chart shows readings for an InstruTech convection gauge (CVG) and Granville-Phillips® Convectron® gauge to illustrate that the difference in the response for both of these types of gauges is virtually indistinguishable.

**CAUTION!** Do not assume this data applies to other convection gauges which may or may not be the same. See [Table 1](#) below and note the following example:

Ex A: If the gas is nitrogen (N<sub>2</sub>), when the true total pressure is 500 Torr, the gauge will read 500 Torr.

Ex B: If the gas is argon (Ar), when the true pressure is 100 Torr, the gauge will read about 9 Torr. If you are backfilling your vacuum system with Ar, when your system reaches a pressure of 760 Torr true pressure your gauge will be reading about 23 Torr. Continuing to backfill your system, attempting to increase the reading up to 760 Torr, you will over pressurize your chamber which may present a hazard.

Ex C: If the gas is helium (He), the gauge will read 1.10E+03 Torr (over pressure indication) when pressure reaches about 10 Torr true pressure and opening the chamber to atmosphere prematurely may present other hazards for both people and product. You probably will not cause damage to your vacuum system, but opening the chamber to atmosphere with the internal chamber pressure at only 10 torr true pressure, may present other hazards for both personnel in the proximity and product that may be inside the chamber/vessel.

**CAUTION!** What these examples illustrate is that using gases other than nitrogen (N<sub>2</sub>) without using accurate gas conversion data and other proper precautions could result in injury to personnel and/or damage to equipment.

***Suggested precautions when using gases other than N<sub>2</sub>:***

- Install a pressure relief valve or burst disk on your chamber to provide protection from the dangers associated with over pressurizing the chamber.
- Post a warning label on your gauge readout such as "Do Not Exceed \_\_\_\_ Torr Indicated Pressure" (fill in the blank for the gas type you are using) so that an operator using the vacuum chamber system and connected gauge will not exceed a safe operating pressure.

 **CAUTION!** Do not assume this data applies to other convection gauges, which may or may not be the same.

 **CAUTION!** Risk of over pressurizing a gas containment vessel and attached apparatus exists when using pressure measurement devices that are calibrated for a specific gas type. Use a pressure relief device to safely limit the internal pressure of a containment vessel to less than the maximum allowable working pressure rating for the vacuum/pressure system and all devices attached to the system.

 **WARNING!** Using a thermal conductivity gauge with gases other than that for which it is calibrated could result in death or serious injury. Be sure to use gas correction data in this manual when measuring pressures of gases other than N<sub>2</sub>/ air.

Exercise caution when admitting positive pressures (above local ambient, atmospheric pressure) of gas into any enclosed volume. Install pressure relief devices on your vacuum / pressure vessel or chamber to limit the maximum allowable working pressure inside the devices and vessel internal volume to less than the lowest rated device - in some cases, the maximum allowable working pressure may be dictated by the type of connections or fittings used to attach devices to your chamber. An O-ring compression fitting type device may be forcibly released (ejected) from the fitting if internal pressure exceeds the local barometric, ambient pressure.

The table below shows the convection gauge displayed readings at various pressures for several commonly used gas types:

**Table 1 - Displayed pressure readings for convection gauge type devices versus true pressure for selected gases**

True Pressure (Torr)	N <sub>2</sub>	Ar	He	O <sub>2</sub>	CO <sub>2</sub>	Kr	Freon12	Freon22	D <sub>2</sub>	Ne	CH <sub>4</sub>
1.00E-4	1.00E-4	1.00E-4	1.00E-4	1.00E-4	1.00E-4	1.00E-4	1.00E-4	1.00E-4	1.00E-4	1.00E-4	1.00E-4
2.00E-4	2.00E-4	2.00E-4	2.00E-4	2.00E-4	2.00E-4	2.00E-4	2.00E-4	2.00E-4	2.00E-4	2.00E-4	2.00E-4
5.00E-4	5.00E-4	5.00E-4	5.00E-4	5.00E-4	5.00E-4	3.00E-4	5.00E-4	5.00E-4	5.00E-4	5.00E-4	5.00E-4
1.00E-3	1.00E-3	7.00E-4	8.00E-4	1.00E-3	1.10E-3	4.00E-4	1.50E-3	1.50E-3	1.30E-3	7.00E-4	1.70E-3
2.00E-3	2.00E-3	1.40E-3	1.60E-3	2.00E-3	2.30E-3	1.00E-3	3.10E-3	3.10E-3	2.40E-3	1.50E-3	3.30E-3
5.00E-3	5.00E-3	3.30E-3	4.00E-3	5.00E-3	4.40E-3	2.30E-3	7.60E-3	7.00E-3	6.00E-3	3.50E-3	7.70E-3
1.00E-2	1.00E-2	6.60E-3	8.10E-3	9.70E-3	1.10E-2	4.80E-3	1.47E-2	1.35E-2	1.21E-2	7.10E-3	1.53E-2
2.00E-2	2.00E-2	1.31E-2	1.61E-2	1.98E-2	2.22E-2	9.50E-3	2.99E-2	2.72E-2	2.43E-2	1.41E-2	3.04E-2
5.00E-2	5.00E-2	3.24E-2	4.05E-2	4.92E-2	5.49E-2	2.35E-2	7.25E-2	6.90E-2	6.00E-2	3.48E-2	7.72E-2
1.00E-1	1.00E-1	6.43E-2	8.20E-2	9.72E-2	1.07E-1	4.68E-2	1.43E-1	1.36E-1	1.21E-1	7.00E-2	1.59E-1
2.00E-1	2.00E-1	1.26E-1	1.65E-1	1.94E-1	2.10E-1	9.11E-2	2.75E-1	2.62E-1	2.50E-1	1.41E-1	3.15E-1
5.00E-1	5.00E-1	3.12E-1	4.35E-1	4.86E-1	4.89E-1	2.17E-1	6.11E-1	5.94E-1	6.87E-1	3.59E-1	7.81E-1
1.00E+0	1.00E+0	6.00E-1	9.40E-1	9.70E-1	9.50E-1	4.00E-1	1.05E+0	1.04E+0	1.55E+0	7.45E-1	1.60E+0
2.00E+0	2.00E+0	1.14E+0	2.22E+0	1.94E+0	1.71E+0	7.00E-1	1.62E+0	1.66E+0	4.13E+0	1.59E+0	3.33E+0
5.00E+0	5.00E+0	2.45E+0	1.35E+1	4.98E+0	3.34E+0	1.28E+0	2.45E+0	2.62E+0	2.46E+2	5.24E+0	7.53E+0
1.00E+1	1.00E+1	4.00E+0	OP	1.03E+1	4.97E+0	1.78E+0	2.96E+0	3.39E+0	OP	2.15E+1	2.79E+1
2.00E+1	2.00E+1	5.80E+0	OP	2.23E+1	6.59E+0	2.29E+0	3.32E+0	3.72E+0	OP	5.84E+2	3.55E+2
5.00E+1	5.00E+1	7.85E+0	OP	7.76E+1	8.22E+0	2.57E+0	3.79E+0	4.14E+0	OP	OP	8.42E+2
1.00E+2	1.00E+2	8.83E+0	OP	2.09E+2	9.25E+0	2.74E+0	4.68E+0	4.91E+0	OP	OP	OP
2.00E+2	2.00E+2	9.79E+0	OP	2.95E+2	1.23E+1	3.32E+0	5.99E+0	6.42E+0	OP	OP	OP
3.00E+2	3.00E+2	1.13E+1	OP	3.80E+2	1.69E+1	3.59E+0	6.89E+0	7.52E+0	OP	OP	OP
4.00E+2	4.00E+2	1.35E+1	OP	4.85E+2	2.24E+1	3.94E+0	7.63E+0	8.42E+0	OP	OP	OP
5.00E+2	5.00E+2	1.61E+1	OP	6.04E+2	2.87E+1	4.21E+0	8.28E+0	9.21E+0	OP	OP	OP
6.00E+2	6.00E+2	1.88E+1	OP	7.30E+2	3.64E+1	4.44E+0	8.86E+0	9.95E+0	OP	OP	OP
7.00E+2	7.00E+2	2.18E+1	OP	8.59E+2	4.61E+1	4.65E+0	9.42E+0	1.07E+1	OP	OP	OP
7.60E+2	7.60E+2	2.37E+1	OP	9.41E+2	5.39E+1	4.75E+0	9.76E+0	1.11E+1	OP	OP	OP
8.00E+2	8.00E+2	2.51E+1	OP	9.97E+2	5.94E+1	4.84E+0	9.95E+0	1.14E+1	OP	OP	OP
9.00E+2	9.00E+2	2.85E+1	OP	OP	7.95E+1	4.99E+0	1.05E+1	1.20E+1	OP	OP	OP
1.00E+3	1.00E+3	3.25E+1	OP	OP	1.11E+2	5.08E+0	1.11E+1	1.27E+1	OP	OP	OP

Values listed under each gas type are in Torr units  
Over Pressure (OP)= 1.10E+03 Torr

When using gases other than nitrogen/air, you must use the above look-up table to determine the true pressures of selected gases as measured by convection gauges. For example, if the gas you are using in your vacuum system chamber is predominately argon (Ar), a displayed pressure of 1.14E+0 Torr means the actual true pressure of argon is 2.00E+00 Torr based on the conversion information provided in the above table.

**Example:** If the gas is argon (Ar), when the true pressure is 100 Torr, the gauge will read only about 9 torr.

## 6 Service

### 6.1 Calibration

Every InstruTech module is calibrated prior to shipment using nitrogen. Care should be exercised when using gases other than nitrogen (N<sub>2</sub>) / air (see previous sections regarding the use of gases other than N<sub>2</sub>/air).

### 6.2 Troubleshooting - IGM400 Operation

<i>Indication</i>	<i>Possible Cause</i>	<i>Possible Solution</i>
LED display on B-RAX controller indicates OFF	No power  The connector may not be wired correctly	Check cable connections and verify that power is being supplied  Check cable connections and verify that power is being supplied
Readings appear very different from expected pressure	Sensor not in the proper location on vacuum system  The process gas is different from the gas (nitrogen) used to calibrate the IGM400  Sensor has been dropped causing mechanical damage  The gauge sensor tube is contaminated  Leak in the vacuum system	Ensure the sensor is located in appropriate location on vacuum chamber  Apply gas sensitivity correction factor if applicable or select the appropriate gas type from the IGM400 display menu  Replace the ion gauge sensor tube  Degas the sensor or replace the sensor  Re-check for leak in the system. Re-check that all metal seals are used when operating below $1.0 \times 10^{-7}$ TORR
Ion gauge cannot be turned on	Pressure exceeds $1 \times 10^{-3}$ TORR at 4 mA emission  Pressure exceeds $5 \times 10^{-2}$ TORR at 0.10 mA (100 $\mu$ A) emission  Emission Control not functioning	Decrease pressure below required value  Decrease pressure below required value  Switch to the other filament replace ion gauge sensor tube due to possible filament failure or contamination
Research screen <sup>2</sup> shows filament voltage is present but filament current stays at 0.00	Filament is open	Switch to the other filament, replace sensor or electronics
Research Screen shows filament voltage and filament current are present but gauge is shutting off	Filament is contaminated or burned out	Switch to the other filament or replace sensor
Unable to initiate degas	System pressure above $5 \times 10^{-5}$ Torr	Decrease pressure below the required value
Voltage to filament too high	Filament contaminated or near end of its life	Switch to the other filament or replace sensor
Setpoint does not actuate	Incorrect setup	Check setpoint setup

<sup>2</sup> See the following sections regarding [setting up the B-RAX LCD display](#) to be in the Research mode and how to [interpret the Research screen](#) display information.

### 6.3 Troubleshooting - IGM400 Error Messages

<i>Indication</i>	<i>Possible Cause</i>	<i>Possible Solution</i>
OVERPRESSURE	The calculated pressure is greater than maximum setting for emission current. System pressure too high	Change to 100 $\mu$ A emission current which will operate at higher pressures or reduce pressure
ION CUR FAIL	The Ion current (IC) is below the minimum parameter. Sensor contamination, possible coating on collector inhibiting ion collection  Electrometer failure	Determine source of contamination Replace the Ion gauge sensor tube  Contact InstruTech
EMIS FAIL	The desired emission current (IE) could not be established.  Gauge contamination, possible coating on filament or grid surfaces.  End of filament life  System pressure too high	Switch to 4mA emission current and attempt repeated filament starts to clean filament  Switch to second filament, degas  Replace the Ion gauge sensor tube  Reduce pressure
LV Failure	The Filament voltage could not be established; Electronics Failure	Contact InstruTech
F1 or F2 OPEN	Filament 1 or 2 is open	Switch to the other filament or replace the Ion gauge sensor tube
F1 or F2 OPEN	Faulty electronics	Replace electronics
CONNECT IGM	IGM400 ion gauge not connected  Faulty cable  Faulty IGM400 electronics	Plug in the IGM400  Replace cable  Replace the IGM400 electronics
COMM IO FAIL	Internal PCB not communicating	Contact InstruTech



**6.4 Troubleshooting - CCM500 Operation**

<b>Indication</b>	<b>Possible Cause</b>	<b>Possible Solution</b>
LED display on B-RAX controller indicates OFF	No power	Check cable connections and verify that power is being supplied
Displayed pressure appears very different from expected pressure	Sensor not in the proper location to measure system pressure	Ensure the sensor is located in appropriate location
	The process gas is different from the gas (nitrogen) used to calibrate the CCM500	Apply gas sensitivity correction factor if applicable
	Sensor has been dropped causing mechanical damage	Replace the Cold Cathode gauge sensor
	The gauge sensor is contaminated	Clean or replace sensor
	Leak in the vacuum system	Re-check for leak in the system; check that all metal seals are used when operating below $1 \times 10^{-7}$ Torr (UHV)
	Incorrect Sensitivity or CAL FACTORS	Ensure correct values programmed
Displayed pressure is significantly lower than expected pressure	The gauge sensor is contaminated	Clean or replace sensor
	Incorrect Sensitivity and CAL FACTORS	Ensure correct values programmed
Gauge cannot be activated (unable to turn anode voltage on)	Pressure exceeds value programmed for OVER PRESSURE in the SETUP IG menu	Decrease pressure below required value
	Chamber pressure higher than $1 \times 10^{-2}$ Torr	Decrease chamber pressure below value programmed for OVER PRESSURE in the SETUP IG menu
Gauge will not start at low pressure	Pressure is too low to initiate discharge	Repeat step to activate sensor
		Increase HV TIMEOUT to allow more time for sensor activation
		Increase pressure
Controller Research Screen shows anode Voltage is present but total current stays at zero	Defective electronics	Repair or replace electronics

### 6.5 Troubleshooting - CCM500 Error Messages

<b>Indication</b>	<b>Possible Cause</b>	<b>Possible Solution</b>
OVERPRESSURE	Pressure exceeds value programmed for OVER PRESSURE in the SETUP IG menu  Chamber pressure higher than $1 \times 10^{-2}$ Torr	Decrease chamber pressure below required value  Decrease chamber pressure below value programmed for OVER PRESSURE in the SETUP IG menu
HV FAILURE	Chamber pressure higher than $1 \times 10^{-2}$ Torr  Defective Electronics	Decrease pressure below $1 \times 10^{-2}$ Torr  Repair or replace electronics
CURRENT FAIL	Sensor contamination  Defective Electronics	Clean or replace sensor  Repair or replace electronics
DISCHARGE FAIL	Electrical discharge has not been established to activate sensor  Defective Electronics	Repeat step to activate sensor  Increase HV TIMEOUT to allow more time for sensor activation  Repair or replace electronics
CONNECT IGM	CCM500 ion gauge not connected  Faulty cable  Faulty CCM500 electronics	Plug in the CCM500  Replace cable  Replace the CCM500 electronics
COMM IO FAIL	Internal PCB not communicating	Contact InstruTech

## 6.6 Clearing Errors

Once the cause of the IG error has been determined and resolved, the IG error must be cleared before the IG filament can be turned on again. To clear errors, follow the steps outlined below:

- 1) Go to the *IG CONTROL* selection of the *SETUP IG* menu and make sure the IG control mode is set to *MANUAL MODE*.
- 2) Next, go to the *IG UNIT ON/OFF* selection of the *SETUP IG* menu and select *OFF* then press the *ENTER* key to save the setting.

***Tips and visual key sequence to clear error :***

The symbol ⇨ implies using the up or down arrow keys to select choice, etc.

You may need to press the *MENU* key one or more times to see the *SETUP IG* selection in the LCD display.

Follow this key sequence to perform the two steps outlined above: Press **MENU** ⇨ **SETUP IG** ⇨ **ENTER** ⇨

**IG CNTL** ⇨ **ENTER** ⇨ **MANUAL MODE** ⇨ **ENTER** :: Now, Press **MENU** ⇨ **UNIT ON/OFF** ⇨ **OFF** ⇨ **ENTER**

See the user manual for either the IGM400 or CCM500 for further instructions on troubleshooting and disassembly of these devices.

## 6.7 Programming the B-RAX for the Research screen in the LCD display

The LCD display of the B-RAX can be setup to display important, critical operating parameters of the IGM400 and CCM500. To setup the B-RAX LCD display to show these important measurements, perform the following key entry and menu choice sequence:

With the IGM400 or CCM500 turned ON (operating and measuring pressure as displayed in the top LED display line),

Press **MENU** ⇒ **SETUP UNIT** ⇒ **ENTER** ⇒ **INFO** ⇒ **ENTER** ⇒

You will see 'BRAX3000' displayed in the LCD display with the 'FIRMWARE = X.YZ' and a menu choice of 'MENU TO EXIT' as shown in the following screen example:

```
BRAX3000
FIRMWARE=
X.YZ
MENU TO EXIT
```

Now, Press and briefly hold the **MENU** and **ENTER** keys **simultaneously** –

if you have done this correctly, the top line of the **INFO** screen, just described above, will change to 'TESTMODE':

```
TESTMODE
FIRMWARE=
X.YZ
MENU TO EXIT
```

Press **MENU** two times (2X) then scroll to the menu choice of 'TEST MODES' ⇒ **ENTER**

Scroll ⇒ **RND SCREEN** ⇒ **ENTER** and change the 'OFF' displayed in the LCD screen to 'ON' by pressing either the down key **↓** or the up key **↑** on the B-RAX front panel.

Now, press **MENU** three times (3X) and you will see the LCD display screen change to RND SCREEN. Refer to the following two sections to review parameters for the IGM400 and CCM500 listed in the RND SCREEN.

**NOTICE** - When using the Research (R&D) display screen, it is intended that the B-RAX only be setup for temporary display of the Research screen. It is not recommended to leave your B-RAX displaying this TEST MODE continuously. By following the above procedure steps for setting up the LCD display to show the R&D display mode, you noticed that at one point you changed the display with only the word OFF indicated to ON. By revisiting the above procedure, change the ON to OFF at that step and the Research display will be turned OFF.

### 6.7.1 Research (R & D) Diagnostic Display - IGM400

In addition to the normal pressure measurement screen the B-RAX provides a diagnostic display screen that allows you to monitor the measurements of the critical electrical parameters used for measurement of very low pressures, i.e., high vacuum, made by the ionization gauge.

Over time, the hot cathode (filament) of the ionization gauge may degrade. The IGM400 coated iridium filaments are made using yttrium oxide to lower the work function of the heated wire material and enable substantial emission of electrons from the hot cathode. These electrons are accelerated in an electric field toward the grid structure of the ionization gauge device. The electron emission is commonly referred to as the 'Emission Current'. As the emission current electrons orbit within the electric field formed by the bias voltages applied to the grid, collector and filament electrodes, the molecules that the gas is comprised of will be ionized by these energetic electrons.

The positive ions that are created within the grid structure are captured in another electric potential field created by the grid structure (at +180 Vdc with respect to ground potential) and the collector wire (at zero volts, i.e., ground potential). In simple terms, the ions collected by the collector electrode (a small diameter wire within the grid electrode structure) are measured with an electrometer circuit connected to the collector. The amount of ion current measured is directly proportional to the density of the gas within the ion gauge transducer. This ion current is commonly referred to as the 'Collector Current'.

From the collector current measured, which is directly proportional to the gas density inside the ion gauge transducer enclosure, the pressure inside the ion gauge transducer can be calculated. The Research display screen is a very useful diagnostic tool to troubleshoot issues with the sensor or the electronics. To access this screen, go to [Section 6.7](#) above describing how to setup the LCD display to show this information.

This mode displays the measured pressure, emission current, ion current, filament voltage and filament current. In the following example, the measured pressure is 1.00E-9 Torr, (pressure unit is based on selected units in SETUP UNIT menu). Emission current is 4.00E-3 amperes, Ion current is 4.00E-11 amperes, filament voltage is 1.5 Vdc and filament current is 1.9 amperes.

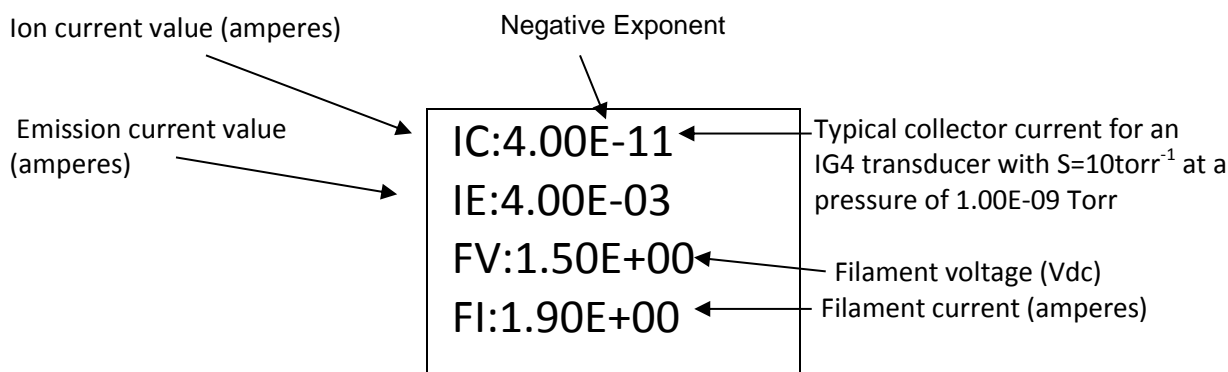

**Example - R&D or Research Display of Critical IGM400 Hot-Cathode Ion Gauge Measurement Parameters**

The Pressure, Ion Current (Collector Current) and Emission Current are indications that the ionization gauge transducer is operating and pressure (vacuum) is being measured. In the above example, most of the critical, measured quantities required for the calculation of measured pressure are displayed. The relationship of these parameters leads to the calculation of pressure given by  $P = I_C \cdot (I_E \cdot S)^{-1}$  where  $I_C$  is the Ion Current,  $I_E$  is the Emission Current and  $S$  is the Sensitivity of the specific ion gauge sensor.

The pressure indication may be checked by using the displayed values and calculating the pressure as indicated by the top LED display line on the B-RAX.

Other important information such as Filament Voltage and Filament Current are also given in the R&D display screen. These values vary widely dependent upon filament design type, material used for constructing the filament, filament condition and operating emission current. The product of the filament voltage and current is the power dissipation ( $V \cdot A$ ) required to maintain the set emission current. The interpretation of these displayed values is a qualitative measure. The values will change over time dependent upon the pressure, filament coating condition and possibly even surface properties of the grid electrode. It is a good practice to make note of these values at initial installation and from time-to-time during the operating lifetime of the ion gauge sensor.

A new IGM400 may operate at 100  $\mu$ A emission current with only 3 to 4 watts of power required (e.g., 1.5 V @ 2.0 A). By increasing the emission current to 4 mA, the power requirement may increase to 4 or 5 watts (e.g., 2.0 V @ 2 to 2.5 A). Again, the values mentioned here are representative; the actual values you may see for the IGM400 you are using will be different and will vary over time and from device to device. In general, keeping a record of the filament heating power (given by the Filament Voltage and Filament Current readings) will aid you in monitoring the condition of your gauge filaments over time and, perhaps, give you an indication of when to schedule replacement of either the device or the filament assembly.

In cases where the ion gauge sensor does not turn ON or does not stay in the ON condition after you have made sure that the pressure is below the maximum permissible pressure for the emission current setting you have chosen, you will be able to monitor the values displayed in the **R&D** screen and determine if the turn ON / stay ON trouble is related to filament condition. There are maximum operating levels for filament voltage and current; if either of these is exceeded, the IGM400 control circuitry will sense the condition and force an OFF condition.

The following table (**R & D (Research) Ion Gauge Diagnostic Display**) is intended to assist you in using the information provided in this display (when using the IGM400) as a means to ascertain if the ion gauge transducer is performing as expected under your vacuum chamber operating conditions. There are various causes of trouble that at times may make it difficult to use a single measurement parameter as an indicator of what the problem is. In general, if you have monitored and recorded the values displayed in the R & D (Research) screen over time, you may be able to detect a pattern or trend that, if correlated to a particular failure mode, may prove to be a valuable indication of probable cause.

The values of filament voltage and current presented below are approximate values that one may see in the Research screen. The representative, average values used in this table may vary depending on the condition of the filament and the vacuum chamber environment. For example, you may see a reading of 2.0 V at 100  $\mu$ A emission current with a corresponding filament drive current of 2.1 A. This doesn't mean that because the voltage is higher than the value listed (1.5 V) above that there is a problem with the IG. The readings taken

should be viewed with the notion that there may be an indication of reaching end-of-useful filament lifetime if the power required to sustain emission current continues to increase over time.

<b>Indication</b>	<b>Possible Cause</b>	<b>Possible Solution</b>
Filament voltage values are present for several seconds immediately after turning IG ON, but then the values are zero	Filament is contaminated or filament has reached end-of-useful operating life for required emission current setting	Switch emission current setting from initial setting and re-start the IG; make several attempts to establish emission current at both 100 $\mu$ A and 4 mA.  Switch to second filament or replace ion gauge sensor
All parameters in the R&D screen are zero after IG turn ON is attempted	Failed electronics	Replace the IGM400 electronics
IGM400 filament voltage is greater than 1.7 V and filament current is greater than 2.5 A with emission current = 100 $\mu$ A	Filament nearing end-of-useful-operating-life	Switch to second filament or replace ion gauge sensor
IGM400 filament voltage is greater than 2.3 V and filament current is greater than 2.7 A with emission current = 4 mA	Filament nearing end-of-useful-operating-life	IGM400 may be operated at either 100 $\mu$ A or 4 mA emission current setting. If trouble with maintaining 4 mA emission current (Ie) persists, switch to 100 $\mu$ A emission current.

### 6.7.2 Research (R & D) Diagnostic Display - CCM500

When you have a CCM500 connected to the B-RAX, the Research (R&D) display screen will show electrometer current (discharge current) and the cold cathode IG anode voltage similar to the following:

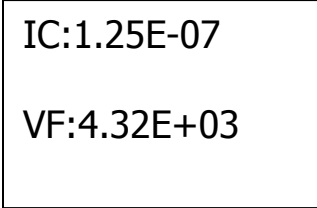

```
IC:1.25E-07
VF:4.32E+03
```

**CCM500 Research (R&D) Screen**

The indication of 'IC:' in the top line of this display is a real time measurement of the cold cathode discharge current. This current is proportional to the density of gas inside the transducer (sensor). The B-RAX front panel indication of pressure is based on this discharge current level. As the gas density increases the discharge current also increases. The pressure reading for the cold cathode ionization gauge is determined by the output of an electrometer circuit in the CCM500, a nominal curve-fit algorithm and a look-up table that resides in the B-RAX controller operating system.

The indication of 'VF:' in the bottom line of this display is a real time measurement of the cold cathode anode voltage. This voltage will change with increasing pressure. If the pressure reading that you see in the B-RAX LED IG display line is lower than expected, these two indications in the R&D screen may be viewed to, perhaps, discern the relative conditions of the measurement being made. If the cold cathode IG has become contaminated, excess electrical current leakage may occur causing the anode voltage to be lower than it should be for the pressure measurement to be realistic. The best practice is to document the discharge current and anode voltage at initial installation of the device then, thereafter at periodic intervals over time at a known operating pressure for your system. In general, your system base pressure may be relatively stable (assuming no leaks have developed and that the vacuum pump is operating at normal pumping capacity). The base or ultimate pressure of your vacuum system may be a good pressure level to periodically check and record the readings displayed in the R&D screen.

## 6.8 Maintenance

In general, maintenance is not required for your InstruTech ion gauge module, convection gauge and control unit. Periodic performance checks may be done by comparing the gauge to a known reference standard. When using the transducer in gases containing contaminants or materials that react with the filaments of the hot cathode ion gauge, periodic degas and switching to the alternate filament from time-to-time is recommended for longest useable transducer lifetime. When the hot cathode (filament) of the ionization gauge transducer is at or near end-of-life, transducer (sensor) replacement is recommended.



## 7 Factory Service and Support

If you need help setting up, operating, troubleshooting, or obtaining a return materials authorization number (RMA number) to return the module for diagnosis, please contact us during normal business hours (8:00am to 5:00pm Mountain time) Monday through Friday, at 303-651-0551. Or e-mail us at [support@instrutechinc.com](mailto:support@instrutechinc.com).

For the safety of our employees, you must download a material disclosure form from our website at [www.instrutechinc.com](http://www.instrutechinc.com). Please use this form to provide a history of the gauge detailing what gases have been used. We cannot work on gauges that have been exposed to hazardous materials.

## 8 Warranty

SELLER warrants that its products are free of defects in workmanship and material and fit for the uses set forth in SELLER's catalog or product specifications, under the normal use and service for which they are intended.

The entire warranty obligation of SELLER is for the repair or replacement, at SELLER's option, of products or parts (examination of which shall disclose to SELLER's satisfaction that it is defective) returned, to SELLER's plant, properly identified within five years after the date of shipment from InstruTech Plant. BUYER must obtain the approval of SELLER and a return authorization number prior to shipment.

Alteration or removal of serial numbers or other identification marks renders this warranty void. The warranty does not apply to products or components which have been abused, altered, operated outside of the environmental specifications of the product, improperly handled or installed, or units which have not been operated in accordance with SELLER's instructions. Furthermore the warranty does not apply to products that have been contaminated, or when the product or part is damaged during the warranty period due to causes other than ordinary wear and tear to the product including, but not limited to, accidents, transportation, neglect, misuse, use of the product for any purpose other than that for which it was designed.

THIS WARRANTY IS EXCLUSIVE AND IN LIEU OF ALL OTHER WARRANTIES, EXPRESS OR IMPLIED, INCLUDING ANY IMPLIED WARRANTY OF MERCHANTABILITY OR FITNESS FOR A PARTICULAR PURPOSE. THIS WARRANTY EXTENDS ONLY IN FAVOR OF THE ORIGINAL BUYER. THE BUYER'S SOLE REMEDY SHALL BE THE REPAIR OR REPLACEMENT, AS IS EXPRESSLY PROVIDED HEREIN, OF ANY WARRANTED DEFECTIVE PRODUCT OR PART, AND UNDER NO CIRCUMSTANCE SHALL SELLER BE LIABLE TO BUYER OR ANYONE ELSE FOR ANY CONSEQUENTIAL DAMAGES TO PERSONS OR PROPERTY, FOR INCIDENTAL DAMAGES OR LOSS OF TIME, FOR ANTICIPATED OR LOST PROFITS, OR ANY OTHER LOSS INCURRED BY THE BUYER RELATED TO THE PRODUCT COVERED BY THIS WARRANTY. THIS EXCLUSIVE REMEDY SHALL NOT BE DEEMED TO HAVE FAILED OF ITS ESSENTIAL PURPOSE SO LONG AS SELLER IS WILLING AND ABLE TO REPAIR OR REPLACE DEFECTIVE PARTS IN THE PRESCRIBED MANNER. THIS LIMITED WARRANTY MAY NOT BE MODIFIED BY SELLER UNLESS SUCH MODIFICATION OR WAIVER IS IN WRITING, EXECUTED BY AN AUTHORIZED OFFICER OF SELLER.



## **InstruTech<sup>®</sup>, Inc.**

1475 S. Fordham St.  
Longmont, CO 80503  
USA

Phone +1-303-651-0551  
Fax +1-303-678-1754  
E-mail [info@instrutechinc.com](mailto:info@instrutechinc.com)  
[www.instrutechinc.com](http://www.instrutechinc.com)